

1st meeting

of the CLUSTER for
BASIC STUDIES FOR
TRANSMUTATION

1st BASTRA meeting

DECEMBER 5, 2001
CERN, GENEVA, SWITZERLAND

VOLUME I

**First meeting of the Basic Studies for Transmutation
BASTRA Cluster
HINDAS / n_TOF-ND-ADS / MUSE / ISTC / OECD-NEA**

Date: **Wednesday 5 December 2001**; Place: **CERN, Geneva, Switzerland**
BUILDING: 864 (Lab 2; Prevessin/F)

Chairman: V. Bhatnagar; Co-chairman: P. Pavlopoulos

08:30	Welcome, Introduction and Approval of the agenda	V. Bhatnagar
08:50	Presentation of the HINDAS Project (10'')	J.-P. Meulders
	Experimental program from 20MeV to 200MeV (20'')	N. Olsson
	Experimental program from 200 MeV to 2 GeV (20'')	K.H. Schmidt
	Theoretical program (20'')	J. Cugnon
10:05	<i>Coffee Break</i>	
10:25	Presentation of the n_TOF-ND-ADS Project (15'')	P. Pavlopoulos
	The CERN Neutron TOF Beam (15'')	A. Zanini
	Experimental Set-up & Preliminary Results (20'')	E. Gonzalez
	Required Precision and Priority List of Elements (10'')	Y. Kadi
	ND Evaluation & Modelling (15'')	H. Leeb
11:40	Presentation of the MUSE Project	R. Soule + W. Gudowski
12:15	Presentation from the Nuclear Data bank NEA/OCDE (Paris) The Route from Experiment to Evaluation	M. Kellett
12:50	<i>Lunch</i>	
14:00	Presentation of the n_TOF ND Evaluation Network	W. Furman
14:15	Presentation of the ISTC projects on Nuclear Data	15'' each
	#B70: Transmutation of LLFP and MA in a Sub-critical Assembly Driven by a Neutron Generator	S. Chigrinov
	#1309: p- and n-induced X-sections of Pb and Neighbouring Nuclei in 20-200 MeV Region	N. Olsson + S. Yavshits
	#1372: Radiochemical and Activation Analysis of LL Nuclear Waste Transmutation in FR and Accelerators	Y. Shubin
	#1971 : n-Induced Fission X-section of Pu240, AM243 and W in the Range of 1-200 MeV	A. Laptev
	#2002 : Yields of Residual Products in Thin Pb and Bi Targets by 40-2600 MeV Protons	V. Batyaev
15:30	<i>Coffee Break</i>	
15:50	Discussion on the needs of nuclear data studies for ADS and coverage by FP5 and other projects	Animated by P. Pavlopoulos
17:30	Actions to be taken	
18:00	Close of the meeting	

List of participants BASTRA Kick-off meeting at CERN, December 5, 2001

Name	Project	Affiliation - Address	Tel. - Fax. - E-mail
AIT ABDERRAHIM Hamid	MUSE, ADOPT	SCK-CEN Boeretang 200 B-2400 Mol	T. 32/14/33 2277 F. 32/14/42 1529 haitabde@sckcen.be
ANDRIAMONJE Samuel	n_TOF-ND-ADS	CEA Saclay DSM/DAPNIA/SPhN F-91191 Gif-sur-Yvette	T. 33/1/690 85688 F. 33/1/690 87584 sandriamonje@cea.fr
BATYAEV Vyacheslav	ISTC - 2002	Laboratory of Fundamental Nuclear Physics Research Institute for Theoretical & Experimental Physics B.Cheremushkinskaya 25, 117218 Moscow, Russia	Tel: +7-095-123-6383, Fax: +7-095-127-0543 E-mail: Yury.Titarenko@itep.ru
BAUMANN Paule	n_TOF-ND-ADS	IReS-IN2P3 Strasbourg-France	T. 33/3/8810 6533 paule.baumann@ires.in2p3.fr
BECVAR Frantisek	n_TOF-ND-ADS	Charles University Prague Vholesovickach 2 CZ-Prague 8	T. 420/2/2191 2566 becvar@mbox.troja.mff.cuni.cz
BERTHIER Bernard	n_TOF-ND-ADS	IPN-IN2P3 Orsay F-91406 Orsay Cedex	T. 33/1/6915 7429 F. 33/1/6915 4507 berthier@ipno.in2p3.fr
BHATNAGAR Ved		European Commission DG RTD Office MO75 5/51 B-1049 Brussels	T. 32/2/299 5896 F. 32/2/295 4991 Ved.Bhatnagar@cec.eu.int
BLOMGREN Jan	HINDAS	Uppsala University Dept of Neutron Research PO Box 525 Uppsala 75120 Sweden	
BORCEA Catalin	n_TOF-ND-ADS	CERN SL/EET CH-1211 Geneva 23	T. 41/22/767 9132 F. 41/22/667 7555 catalin.borcea@cern.ch
BROEDERS Cornelis	MUSE + ISTC B70, 1309, 1372, 2002	FZK Postfach 3640 D-76021 Karlsruhe	T. 49/7247/822484 F. 49/7247/823718 cornelis.broeders@irs.fzk.de
CALVINO Francisco	n_TOF-ND-ADS	Nuclear Engineering, ETSEIB-UPC Diagonal 647 E-08028 Barcelona	T. 34/9340 17143 F. 34/9340 17148 Francisco.Calvino@upc.es
CENNINI Paolo	n_TOF-ND-ADS	CERN CH-1211 Geneva 23	T. 41/22/767 9296 F. 41/22/767 7555 Paolo.Cennini@cern.ch
CHIGRINOV Sergey	ISTC - B 070	Scientific & Technical Centre "Sosny" NAS Minsk-Sosny, 220 109 Belarus	T. 375/172 467512 F. 375/172 467712 S.Chigrinov@SOSNY.BAS-NET.BY
COLONNA Nicola	n_TOF-ND-ADS	INFN Bari Bari, Italy	T. 39/80/544 2351 F. 39/80/544 2470 nicola.colonna@ba.infn.it
CUGNON Joseph	HINDAS	University of Liège Institute of Physics B.5 Allée du 6 Août 17 B-4000 Sart Tilman, par Liège 1	T. 32/4/366 3601 F. 32/4/366 3672 J.Cugnon@ulg.ac.be
DAHLFORS Marcus	n_TOF-ND-ADS	CERN ZO 3000 CH-1211 Geneva	T. 41/22/767 5492 F. 41/22/767 7555 marcus.dahlfors@cern.ch
D'HONDT Pierre	ADOPT	SCK-CEN Boeretang 200 B-2400 Mol	T. 32/14/332200 F. 32/14/321529 phdondt@sckcen.be
DURAN Ignacio	n_TOF-ND-ADS	Santiago de Compostela University E-15706 Santiago de Compostela	duran@fpddux.usc.es
FURMAN Walter	n_TOF-ND-ADS	JINR 141980 Dubna, Moscow Region Russia	T. 7/096/2166865 F. 7/096/2165425 furman@nf.jinr.ru
GONZALEZ-ROMERO Enrique	n_TOF-ND-ADS	CIEMAT Anda Complutense, 22 E-28040 Madrid	T. 34/91/346 6118 F. 39/91/346 6576 enrique.gonzalez@ciemat.es
GUDOWSKI Waclaw	MUSE, ADOPT	KTH Stockholm Royal Institute of Technology S-106 91 Stockholm	T. 46/8/5537 8200 F. 46/8/5537 8465 mobile : 46/73/656 0887 wacek@neutron.kth.se

List of participants BASTRA Kick-off meeting at CERN, December 5, 2001

Name	Project	Affiliation - Address	Tel. - Fax. - E-mail
AIT ABDERRAHIM Hamid	MUSE, ADOPT	SCK-CEN Boeretang 200 B-2400 Mol	T. 32/14/33 2277 F. 32/14/42 1529 haitabde@sckcen.be
GUNSING Frank	n_TOF-ND-ADS	CEA Saclay DSM/DAPNIA/SPhN F-911191 Gif-sur-Yvette	T. 33/1/6908 7523 F. 33/1/6908 7584 gensing@cea.fr
HADDAD Ferid	HINDAS	Subatech B.P. 20722 La Chantrerie, rue A. Kastler F-44307 Nantes	T. 33/2/5185 8467 F. 33/2/5185 8424 haddad@subatech.in2p3.fr
HEIL Michael	n_TOF-ND-ADS	FZK H. von Helmholtz Platz 1 D-76344 Eggenstein	T. 49/7247/82 3984 F. 49/7247/82 4075 heil@ik3.fzk.de
HUGON Michel		European Commission DG RTD Office MO75 5/55 B-1049 Brussels	T. 32/2/2965719 F. 32/2/2954991 Michel.Hugon@cec.eu.int
KADI Yacine	n_TOF-ND-ADS	CERN SL/EET CH-1211 Geneva 23	T. 41/22/767 9569 F. 41/22/767 7555 Yacine.Kadi@cern.ch
KÄPPELER Franz	n_TOF-ND-ADS	FZK, IK D-76021 Karlsruhe	T. 49/7247/3991 kaepp@ik3.fzk.de
KELLETT Mark	NEA	OECD Nuclear Energy Agency 12, bd. Des Iles F-92130 Issy-les-Moulineaux	T. 33/1/4524 1085 F. 33/1/4524 1110 kellett@nea.fr
LACOSTE Véronique	n_TOF-ND-ADS	CERN Z.O. 3000 CH-1211 Geneva 23	T. 41/22/767 8165 F. 41/22/767 7555 veronique.lacoste@cern.ch
LAPTEV Alexander	ISTC 1971	Petersburg Nuclear Phys. Institute Gatchina, Leningrad Region 188 300 Russia	T. 7/812/71 46444 F. 7/812/71 36041 laptev@pnpi.spl.ru
LE BRUN Christian	MUSE	ISN Grenoble 53, avenue des Martyrs F-38026 Grenoble	T. 33/1/7628 4190 F. 33/1/7628 4004 lebrunch@isn.in2p3.fr
LEEB Helmut	n_TOF-ND-ADS	Atominstitut d.Österr.Universitäten Technische Universität Wien Wiedner Hauptstrasse 8-10 A-1040 Wien	T. 43/1/58801/14258 F. 43/1/58801/14299 leeb@kph.tuwien.ac.at
MENGGONI Alberto	n_TOF-ND-ADS	ENEA Applied Physics Div. V. Don Fiammelli, 2 I-40129 Bologna	T. 39/51/609 8306 mengoni@bologna.enea.it
MEULDERS Jean-Pierre	HINDAS	Université Catholique de Louvain Institut de Physique Nucléaire Chemin du Cyclotron, 2 B-1348 Louvain-la-Neuve	T. 32/10/47 3273 F. 32/10/45 2183 Meulders@fyuu.ucl.ac.be
MICHEL Rolf	HINDAS	Universität Hannover Zentrum für Strahlenschutz und Radioökologie Am Kleinen Felde 30 D-30167 Hannover	T. 49/571/762 3312 F. 49/511/762 3319 michel@ZSR.UNI-HANNOVER.DE
OLSSON Nils	HINDAS	Uppsala University Dept of Neutron Research PO Box 525 Uppsala 75120 Sweden	T. 46 18 471 3043 F. 46 18 471 3853 Nils.Olsson@tsl.uu.se
PANCIN Julien	n_TOF-ND-ADS	CEA - CERN CH-1211 Geneva 23	T. 42/22/767 9886 julien.pancin@cern.ch
PARADELA Carlos	n_TOF-ND-ADS	Santiago de Compostela University Facultad de fisica E-15706 Santiago de Compostela	T. 34/981/563 100 F. 34/981/ext. 14000 paradela@fddux.usc.es
PAVLOPOULOS Panagiotis	n_TOF-ND-ADS	Univ. of BASLE and CERN CH-1211 Geneva 23	T. 41/22/767 9564 & 41/79/201 0119 F. 41/22/767 7555 Noulis.Pavlopoulos@cern.ch
PLAG Ralf	n_TOF-ND-ADS	FZK H. von Helmholtz Platz 1 D-76344 Eggenstein	T. 49/7247/823984 F. 49/7247/824075 ralf.plag@ik.fzk.de
RAPP Wolfgang	n_TOF-ND-ADS	FZK H. von Helmholtz Platz 1 D-76344 Eggenstein	T. 49/7247/823 986 wrapp@ik3.fzk.de
REIFARTH René	n_TOF-ND-ADS	FZK H. von Helmholtz Platz 1 D-76344 Eggenstein	T. 49/7247/82 3984 F. 49/7247/82 4075 reifarth@ik3.fzk.de

List of participants BASTRA Kick-off meeting at CERN, December 5, 2001

Name	Project	Affiliation - Address	Tel. - Fax. - E-mail
AIT ABDERRAHIM Hamid	MUSE, ADOPT	SCK-CEN Boeretang 200 B-2400 Mol	T. 32/14/33 2277 F. 32/14/42 1529 haitabde@sckcen.be
RUDOLF Gérard	n_TOF-ND-ADS	IReS-IN2P4 Strasbourg-France	T. 33/3/8810 6290 gerard.rudolf@ires.in2p3.fr
RULLHUSEN Peter	n_TOF-ND-ADS	IRMM Retieseweg D-2440 Geel	T. 32/14/571 476 F. 32/14/571 862 peter.rullhusen@irmm.irc.be
SHUBIN Yuri	ISTC - 1372	State Scientific Centre of Russian Federation, Institute of Physics and Power Engineering (SSC RF -IPPE), Bondarenko Sq 1, Obninsk 249033 RF	Tel: +7 (08439) 98611 Fax: +7 (08439) 68225 shubin@ippe.obninsk.ru
SCHMIDT Karl-Heinz	HINDAS	GSI Planckstrasse 1 D-64291 Darmstadt	T. 49/6159/712 739 F. 49/6159/712 785 K.H.Schmidt@gsi.de
SLYPEN Isabelle	HINDAS	Université Catholique de Louvain Institut de Physique Nucléaire Chemin du Cyclotron, 2 B-1348 Louvain-la-Neuve	T. 32/10/47 3208 F. 32/10/45 2183 slypen@fyynu.ucl.ac.be
SOULE Roland	MUSE	CEA Cadarache DER/SPEX/LPE Building 238 F-13108 St. Paul-lez-Durance	T. 33/4/4225 4077 F. 33/4/4225 7025 roland.soule@cea.fr
STEPHAN Claude	n_TOF-ND-ADS	IPN-IN2P3 Orsay F-91046 Orsay Cedex	T. 33/1/6915 7429 F. 33/1/6915 4507 stephan@in2p3.fr
TITARENKO Yuri	ISTC - 2002	Head of Laboratory of Fundamental Nuclear Physics Research Institute for Theoretical & Experimental Physics B. Cheremushkinskaya 25, 117218 Moscow, Russia	Tel: +7-095-123-6383, Fax: +7-095-127-0543 E-mail: Yury.Titarenko@itep.ru
VLACHOUDIS Vasilis	n_TOF-ND-ADS	CERN Div. SL CH-1211 Geneva 23	T. 41/22/767 9851 F. 41/22/767 7555 Vasilis.Vlachoudis@cern.ch
VOSS Friedrich	n_TOF-ND-ADS	FZK H. von Helmholtz Platz 1 D-76344 Eggenstein	T. 49/7247/82 3986 F. 49/7247/82 4575 voss@ik3.fzk.de
WENDLER Helmut	n_TOF_ND_ADS	EP Division CERN CH-1211 Geneva 23	Tel.: +41 22 767 3851 GSM.: +41 79 201 0565 Fax.: +41 22 767 3020 Helmut.Wendler@cern.ch
YAVSHITS Sergey	ISTC 1309	V.G. Khlopin Radium Institute 2nd Murinsky, 28 194021 St. Petersburg Russia	T. 7/812/552 0185 F. 7/812/247 8095 yav@mail.rcom.ru
ZANINI A	n_TOF_ND_ADS	EP Division CERN CH-1211 Geneva 23	T. 41/22/767 5461 F. 41/22/767 7555 Luca.Zannini@cern.ch

EXECUTIVE SUMMARY (Short Minutes)

Extract from Ved Bhatnagar's Mission report (internal)

The meeting proceeded with brief presentations of the three projects: HINDAS, n_TOF_ND_ADS and MUSE. In each case, the co-ordinators briefly outlined the objectives and scope of the work to be carried out in their projects followed by presentations made by work package leaders on the tasks that they are responsible for. Presentations were also made by 5 ISTC projects in this area including the one from Nuclear Data Centre at NEA. The aim of the discussion during and after the presentations was to highlight the issues that are of importance for nuclear data needs for an ADS and in particular the ones that are not being addressed in the presently running FP5 projects.

The main points of the discussion can be summarised as follows (Partially based on the slide that Noulis Pavlopoulos presented in the discussion)

- The Commission's initiative of clustering of related FP5 projects and facilitating exchange of information was highly appreciated. It was more so for the BASTRA cluster as not only the FP5 projects but also the ISTC related projects and OECD/NEA participation made the meeting more valuable.
- The nuclear (cross section) data bank at NEA/OECD is dealing with all kinds of cross section data, for all kinds of isotopes, in all energy ranges and for all kinds of applications. This has led to a mammoth job which is becoming somewhat unwieldy and puts people off.
- It was suggested that the BASTRA cluster focus on the specific needs of nuclear cross section data for Accelerator Driven Systems for P&T. This implies reiterating (some information is already available from NEA) and listing the (Z,A) of the isotopes, nuclear reaction mechanisms and the energy range for which this data is required.
- There is a need to review and take stock of the situation of the data that already exist, the data that is being acquired and planned during the present FP5 and other projects on nuclear data. This would culminate in defining properly the future needs and efforts required in this direction. A sub group is proposed to be set up to work it out and for reporting (see below).
- It was suggested that the input data should have to be filtered by a quality control system (or criteria) before it is accepted for dissemination via the Nuclear Data for ADS (NUDADS) databank (name coined by myself!) possibly managed by NEA/OECD. The quality control parameters should be defined and may include $\Delta E/E$, precision, completeness parameters etc.
- There should be more complete horizontal activities relating to interactions between authors of different theoretical models including transport codes so that they can sort out the reasons for discrepancies among different evaluations that are

accepted in the dedicated ADS database. In this context, source codes should be made available to other with due care of IPRs.

- There should be collaborative efforts so that specialists in certain areas or those implementing specialised techniques may also perform tests or measurements on samples coming from other institutions.
- Efforts should be made via financing of the fellowships such as Marie Curie or others so that young scientists are attracted to the field of nuclear data evaluation as veteran scientists become unavailable through natural wastage.
- It is proposed to establish several subgroups (2 or 3 persons each) which will report back to the cluster chairman on certain specific topics such as: (a) ADS designers' requirements for the nuclear data, (b) Sensitivity studies on nuclear cross section data, (c) Overlap of work being done at FP5 and ISTC projects in nuclear data, (d) Theoretical models etc.

The next meeting of the cluster is informally proposed (to be confirmed) to take place in Uppsala, Sweden on 13/14 September 2002 together with the progress meeting of HINDAS project.



BASIC STUDIES on TRANSMUTATION

BASTRA Cluster Meeting

V.P. BHATNAGAR

Nuclear Fission and Radiation Protection
Unit J.4, DG Research

European Commission

Brussels

e-mail: Ved.Bhatnagar@cec.eu.int



EURATOM



Clustering of P&T Projects

- ◆ EC is organising several clusters of complementary FP5 P&T projects to maximise European added value.
- ◆ The clusters are expected to optimise:
 - Scientific Networking
 - Coordination
 - Exchange of information
 - Monitoring
 - Exploitation and
 - Dissemination activities





Table 1. Clusters for the Funded FP5 Projects on Partitioning and Transmutation

Acronym	Project Title	Start Date Duration	EC Budget (M?)	Coordinator
PARTITIONING (Cluster PARTITION)				
PYROREP	Pyro-metallurgical Processing Research Programme	1/9/2000 36 months	1.5	Mr H. Boussier CEA, (F)
PARTNEW	New Solvent Extraction Processes for Minor Actinides	1/9/2000 36	2.2	C. Madic CEA (F)
CALIXPART	Selective Extraction of Minor Actinides from High Activity Liquid Waste by Organized matrices	1/10/200 36	1.3	J-F. Dozol CEA (F)
TRANSMUTATION : BASIC STUDIES (Cluster BASTRA)				
MUSE	The MUSE experiments for sub-critical neutronics validation	1/10/2000 36	2.0	Mr R. Soule CEA (F)
HINDAS	High and intermediate energy nuclear data for accelerator driven systems	1/9/2000 36	2.1	Mr J-P. Meulders UCL (B)
N_TOF_ND_ADS	ADS nuclear data	1/11/2000 36	2.4	Mr P. Pavlopoulos CERN (CH)
TRANSMUTATION : TECHNOLOGICAL SUPPORT (Cluster TESTRA)				
SPIRE	Irradiation effects in Martensitic Steels under neutron and proton mixed spectrum	1/8/2000 48	2.3	Mr J-L. Boutard CEA (F)
TECLA	Technologies, Materials and Thermal Hydraulics for Lead alloys	1/9/2000 36	2.5	Mr G. Benamati ENEA (I)
MEGAPIE-TEST	Megawatt Pilot Experiment -Test	1/11/2001 36	2.4	Mr J. Knebel FZK (D)
FUELS (Cluster FUETRA)				
CONFIRM	Uranium free fuels for ADS: Collaboration on oxide and nitride fuel irradiation and modeling	1/9/2000 48	1.0	Mr J. Wallenius KTH (S)
THORIUM CYCLE	Development steps for PWR and ADS applications	1/10/2000 48	1.2	Mr. R. Schram NRG (NL)
FUTURE	Fuels for Transmutation of Transuranium Elements	1/12/2001 36	1.7	Ms. S. Pillon CEA (F)





Aims of Cluster Meeting

- ◆ Information Exchange of related projects
- ◆ Improve and complement the Work programme within the overall constraints of the projects
- ◆ Discuss the needs of nuclear data and sub-critical neutronic studies for an ADS
- ◆ Help in preparing the future areas of basic studies for ADS
- ◆ Help in Organizing consortiums so that they can prepare possible proposals for FP6



EURATOM



BASTRA Cluster

- ◆ **An opportunity to invite related ADS nuclear data actors to participate in the cluster meeting:**
 - **EURATOM 5th Framework Programme Projects**
 - **International Science and Technology Centre (ISTC) Moscow**
 - **Nuclear Energy Agency (NEA), Paris of Organisation for Economic Co-operation and Development (OECD)**



EURATOM



BASTRA Cluster Projects

◆ EC FP5 Projects

- **HINDAS** : High and Intermediate Energy Nuclear Data for Accelerator Driven Systems: **J.-P. Meulders et al.**, UCL, Louvain-la-Neuve, Belgium
- **N_TOF_ND_ADS**: Time-of- Flight ADS nuclear data : **P. Pavlopoulos et al.**, CERN, Geneva, Switzerland
- **MUSE**: The MUSE Experiments for Sub-critical Neutronics Validation : **R. Soule** et al., CEA, Cadarache, France



EURATOM



Other Projects

◆ ISTC Projects

- **#B70** : Experimental and Theoretical Research on Transmutation of Long-Lived Fission Products and Minor Actinides in a Subcritical Assembly Driven by a Neutron Generator: **S. Chigrinov et al.**, Radiation Physics and Chemistry Problems Institute, Minsk-Sosny, Belarus
- **#1309** : Measurements and Comparison of p- and n-induced Cross sections of Lead and Neighboring Nuclei in the 20-200 MeV Region: **S. Yavshits et al.**, V.G. Khlopin Radium Institute, St Petersburg, Russia
- **#1372** : Complex Radiochemical and Activation Analysis of Long Life Nuclear Waste Transmutation in Fast Reactors and in Beams of High Energy Accelerators : **Y. Shubin et al.**, State Scientific Centre of RF, Institute of Physics and Power Engineering, Obninsk, Russia



EURATOM



Other Projects

◆ ISTC Projects (continued)

- **#1971** : Neutron Induced Fission Cross section of PU240, AM 243 and W in the range of 1-200 MeV : **A. Laptev et al.**, Petersburg Nuclear Physics Institute Gatchina, Leningrad District, Russia
- **#2002** : Experimental and Theoretical Studies of the yields of Residual Products in Thin Pb and Bi Targets by 40-2600 MeV Protons: **Y. Titarenko et al.**, Institute of Theoretical and Experimental Physics (ITEP), Moscow, Russia



EURATOM

Projects on ADvanced Options for Partitioning and Transmutation (**ADOPT**)

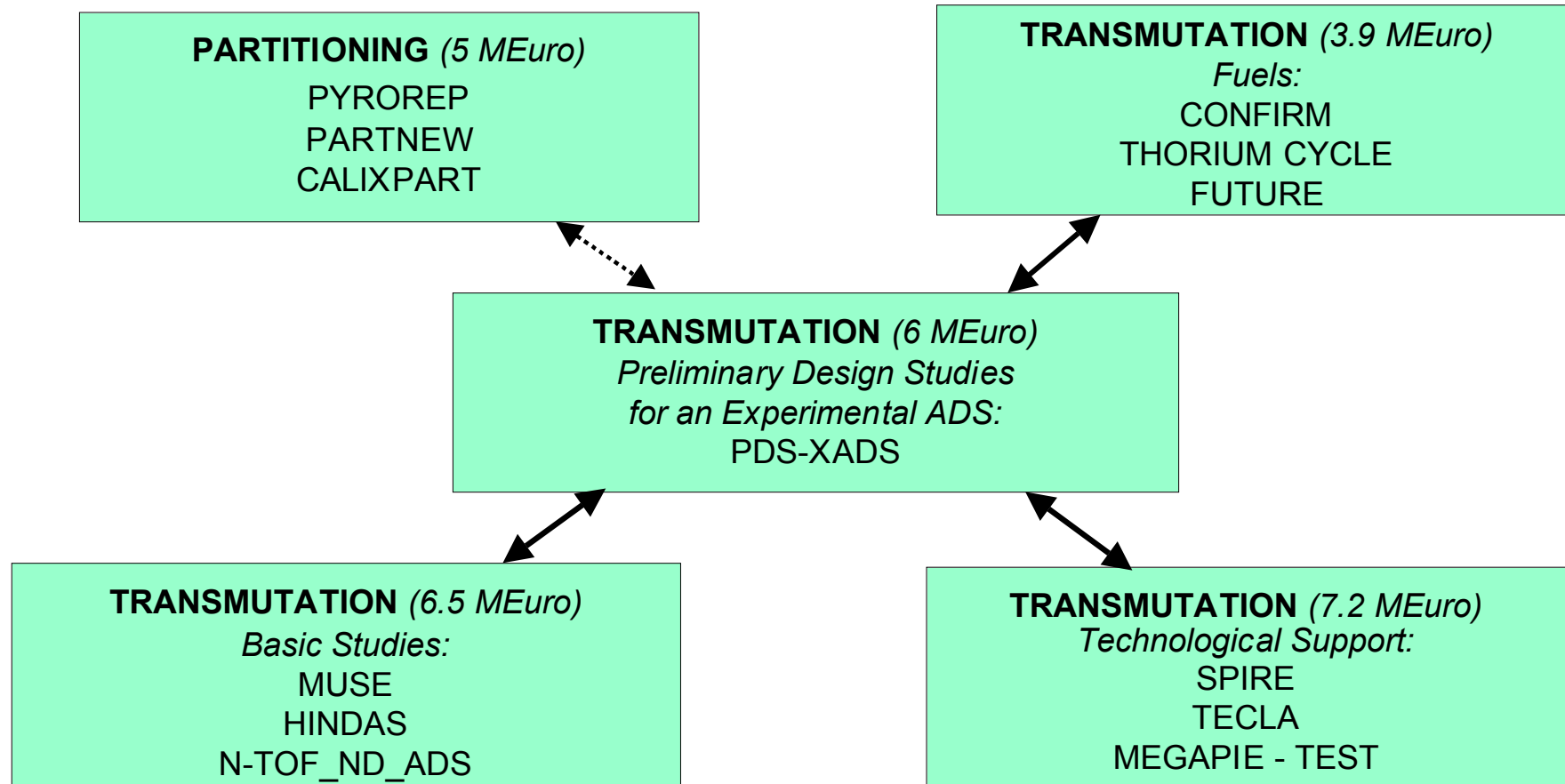

High and Intermediate energy Nuclear Data for Accelerator-driven Systems

HINDAS

List of participants

- **Belgium**
 - Université Catholique de Louvain (UCL) Louvain-la-Neuve (**Jean-Pierre Meulders**)
 - Université de Liège (Ulg) (**Joseph Cugnon**)
- **France**
 - Laboratoire de Physique Subatomique et des Technologies Associées (SUBATECH) Nantes (**Philippe Eudes**)
 - Laboratoire de Physique corpusculaire de Caen (LPC-Caen) (**Jean-Francois Lecolley**)
 - CEA -SACLAY (**Sylvie Leray**)
 - CEA- Centre d 'Etudes de Bruyères-le-Châtel (**Olivier Bersillon**)
- **Germany**
 - Universitaet Hannover - Zentrum für Strahlenschutz und Radioekologie (ZSR) (**Rolf Michel**)
 - Physikalisch-Technische Bundesanstalt- Department « Ionising Radiation » (PTB) (**Helmut Schuhmacher**)
 - Forschungszentrum Jülich GmbH - Institut für Kernphysik (FZJ-IKP) (**Detlef Filges**)
 - Gesellschaft für Schwerionenforschung - Kernphysik II (GSI) (**Karl-Heinz Schmidt**)
- **Netherlands**
 - Rijksuniversiteit Groningen - Kernfysisch Versneller Instituut (KVI) (**Hans Beijers**)
 - Nuclear Research and consultancy Group (NRG Petten) (**Arjan Koning**)
- **Sweden**
 - Uppsala Universitet - Department of Neutron Research (UU) (**Nils Olsson- Elisabet Ramstrom**)
- **Spain**
 - Universidade de Santiago de Compostela (**Jose Benlliure**)
- **Switzerland**
 - ETH Zürich - Institute of Particle Physics (**Hans-Arno Sytal**)
 - Paul Scherrer Institut (**Regin Weinreich**)

HINDAS

Scientific Objectives

- Most complete set of new experimental data between 20 MeV and 2 GeV
- Selected targets:
 - Fe as shielding material
 - Pb as target material
 - U as element representative of the actinides
- Improvement and benchmarking of existing nuclear models or development of new codes

HINDAS

List of European facilities and laboratories

- Experiments at energies below 200 MeV

- Institut de physique nucléaire, Université catholique de Louvain (UCL), [Louvain-la-Neuve, Belgium](#) (CYCLONE cyclotron)
- The Svedberg Laboratory, Uppsala Universitet, [Uppsala, Sweden](#) (cyclotron)
- Kernfysisch Versneller Instituut , Rijksuniversiteit Groningen - [Groningen, The Netherlands](#) (cyclotron)
- Paul Scherrer Institut , [Villingen, Switzerland](#) (cyclotron)

users

- Laboratoire de Physique Subatomique et des Technologies Associées (SUBATECH) [Nantes, France](#).
- Laboratoire de Physique corpusculaire de Caen (LPC-Caen), [Caen, France](#).
- Zentrum für Strahlenschutz und Radioökologie (ZSR), Universitaet Hannover, [Hannover, Germany](#).
- Physikalisch-Technische Bundesanstalt- Department « Ionising Radiation » (PTB) [Braunschweig, Germany](#).
- ETH Zürich - Institute of Particle Physics , [Zürich, Switzerland](#)

- Experiments at energies above 200 MeV

- Gesellschaft für Schwerionenforschung, Kernphysik II, [GSI Darmstadt, Germany](#) (heavy ion synchrotron)
- Institut für Kernphysik, Forschungszentrum Jülich GmbH - [FZJ Jülich, Germany](#) (Storage and cooler synchrotron)

users

- CEA -SACLAY , [Saclay, France](#).
- Universidade de Santiago de Compostela, [Santiago de Compostela, Spain](#).

- Theory

- Institut de Physique, Université de Liège (Ulg), [Liège, Belgium](#).
- Nuclear Research and consultancy Group (NRG Petten), [Petten, The Netherlands](#)
- CEA- Centre d 'Etudes de Bruyères-le-Châtel, [Bruyères-le-Châtel, France](#)
- Department of Neutron Research, Uppsala Universitet , [Nyköping, Sweden](#)

HINDAS

Presentation

- Experiments at energies between 20 and 200 MeV

Nils Olsson, UU - Uppsala

- Experiments at energies above 200 MeV

Karl Heinz Schmidt, GSI - Darmstadt

- Theoretical studies

Joseph Cugnon, ULg - Liège

HINDAS
Experimental Programme from
20 MeV to 200 MeV

N. OLSON

HINDAS – WP 1, 2 and 3

Measurements between 20 and 200 MeV

- Few, selected nuclei (Fe, Pb, U)
- As many reactions as possible
- Analysis – Improved models (WP 7)
- Data base (WP 7)

Workpackages

WP 1: n- or p-induced light charged-particle production cross sections (lead: University of Nantes)

Experiments: UCL, UU, KVI

WP 2: n- or p-induced neutron production cross sections (lead: University of Uppsala)

Experiments: UCL, UU

WP 3: n- or p-induced residual nuclide production and production of long-lived radionuclides (lead:

University of Hannover)

Experiments:

PSI, UCL, UU + others

Experimental facilities

- UCL: Protons, 20 – 70 MeV
Neutrons (quasimonoenergetic), 20 – 70 MeV
- UU/TSL: Protons, 20 – 180 MeV
Neutrons (quasimonoenergetic), 20 – 180 MeV
- KVI: Protons, 20 – 190 MeV
- PSI: Protons, 45 – 70 MeV
- ETH Zürich: EN Tandem for AMS

Experimental techniques

- Charged particle production cross sections:
 1. Particle telescopes (e.g., MEDLEY)
 2. Particle tracking (e.g., SCANDAL)
- Neutron production cross sections:
 1. Time-of-flight
 2. Conversion to recoil protons + proton tracking
- Residual production:
 1. Activity spectroscopy
 2. Chemical separation + accelerator mass spectroscopy

MEDLEY facility

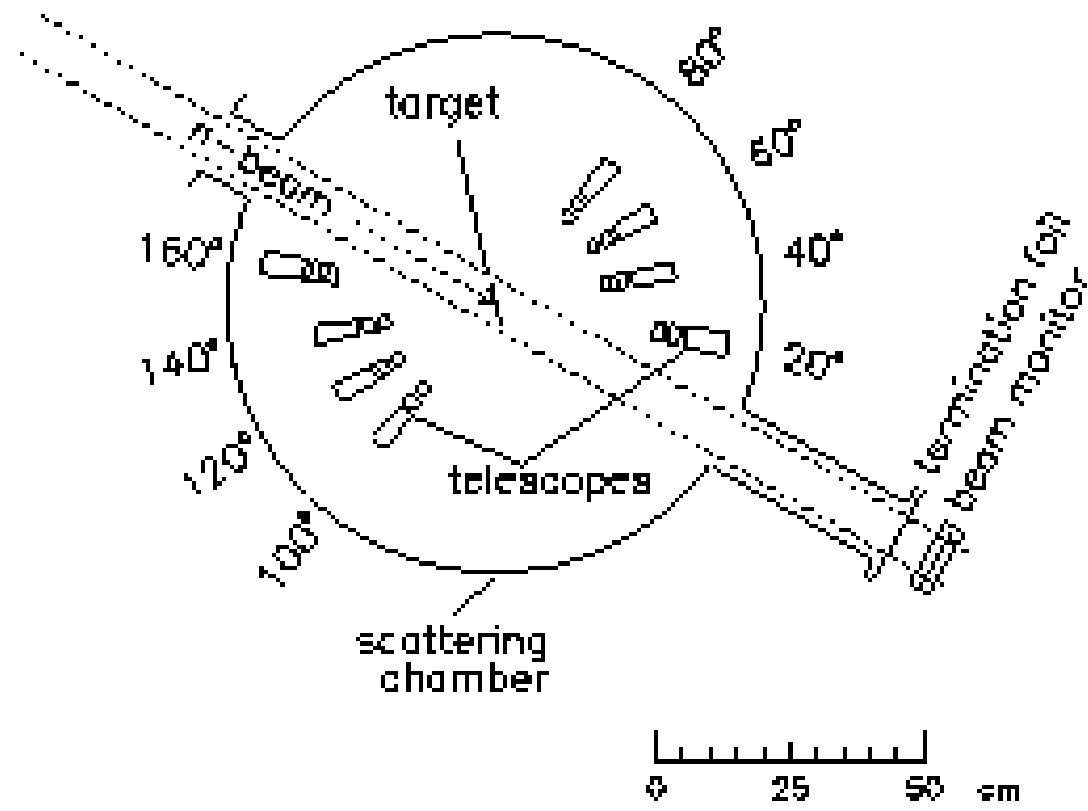

MEDLEY telescope

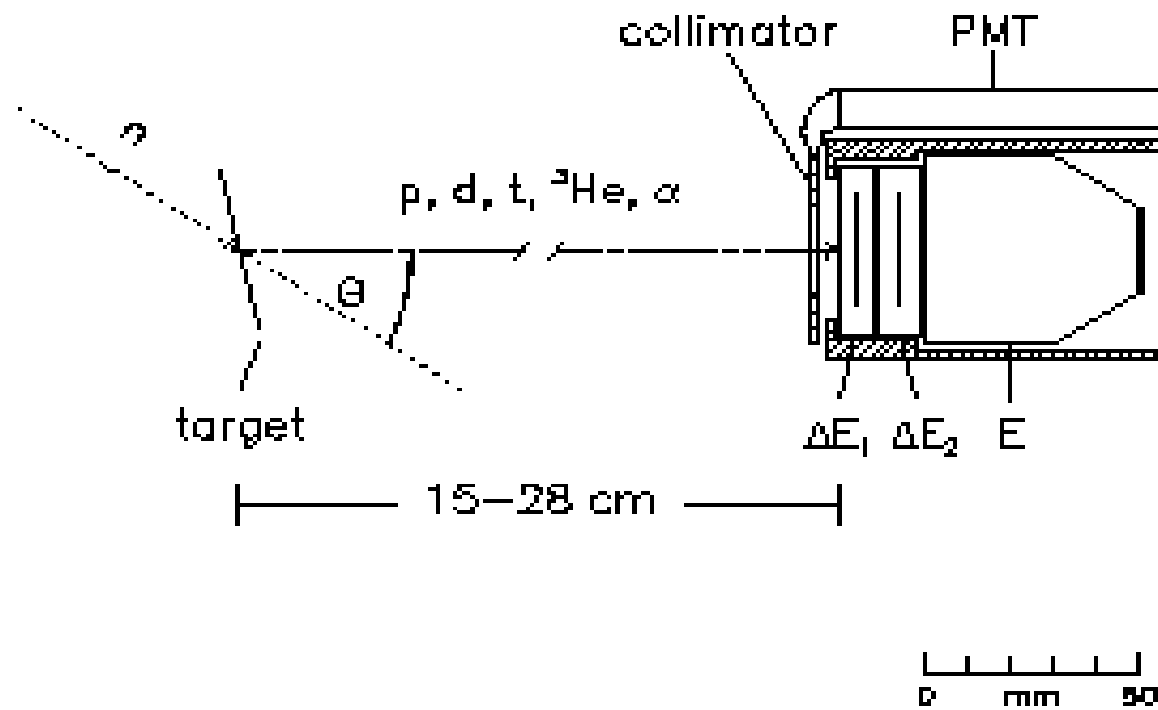

SCANDAL facility

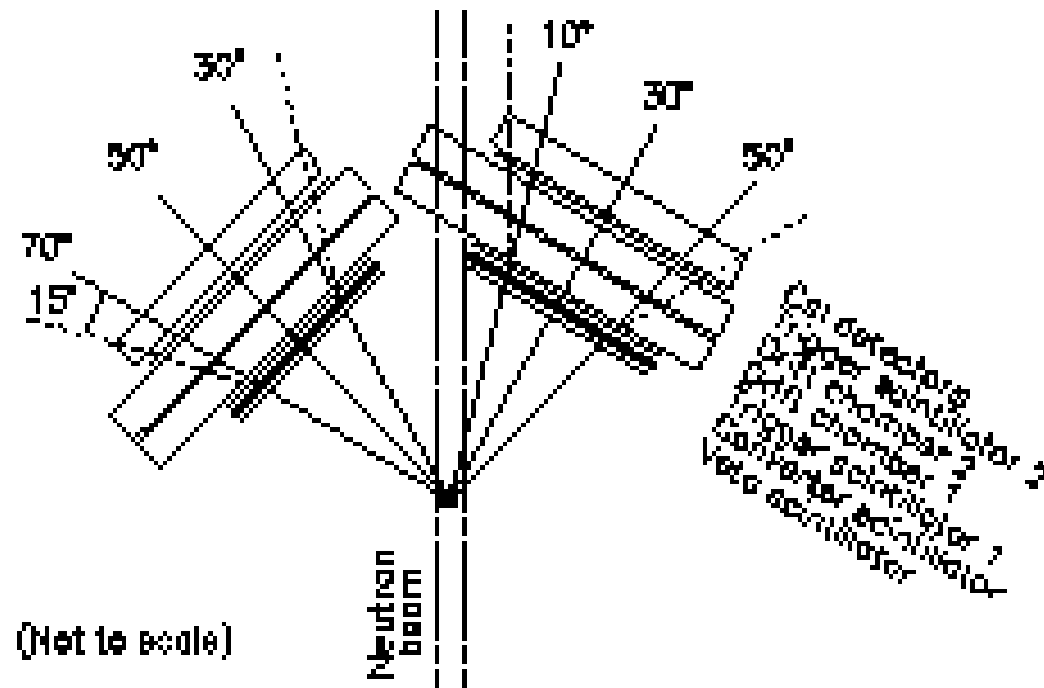

Preliminary results....

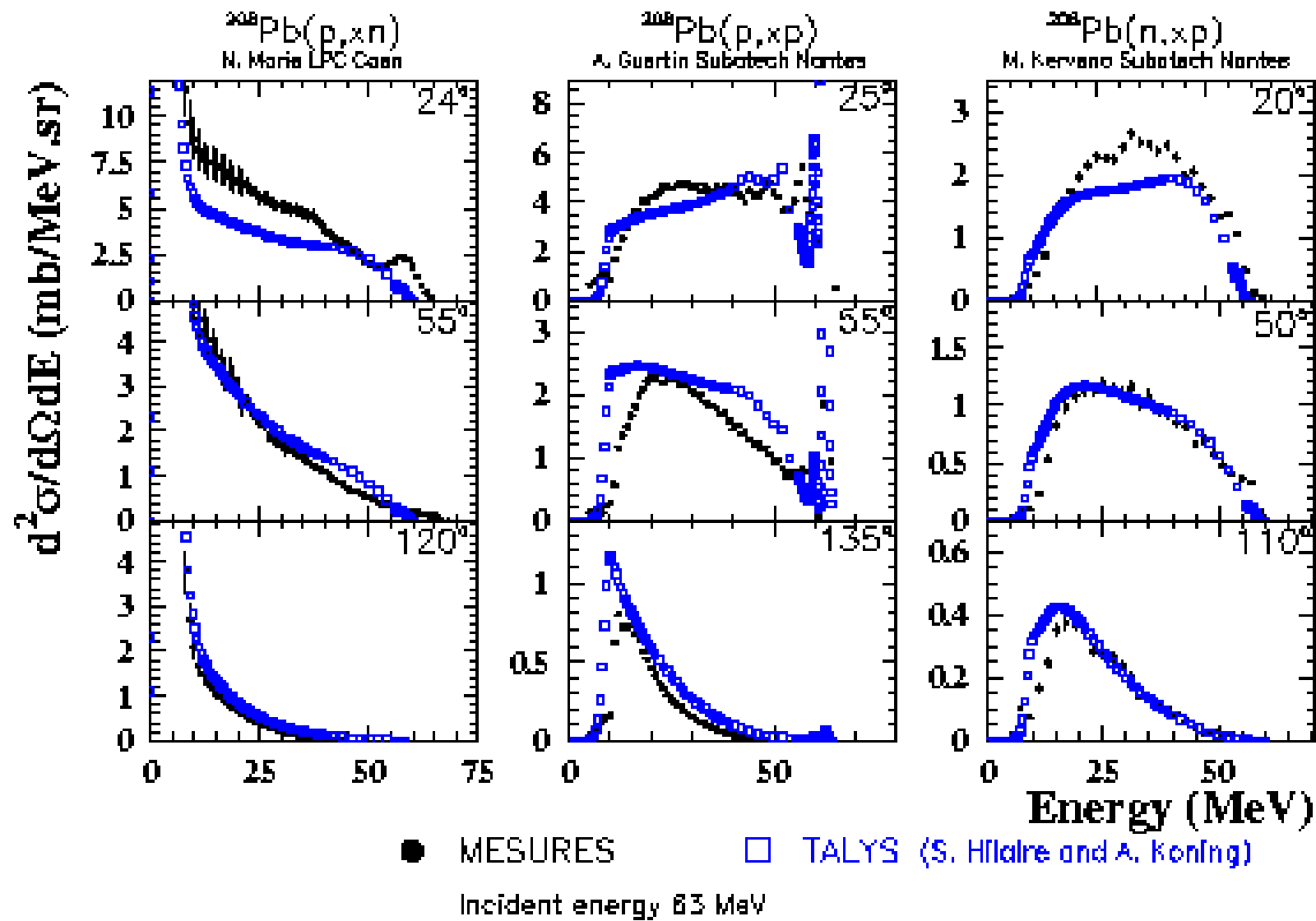

- FLJF neutron induced data on ^{17}O
- FLJF neutron induced data on ^{17}O
- proton induced data on ^{17}O (Krauss and Finkle 1973)

Laboratory angle : 30°

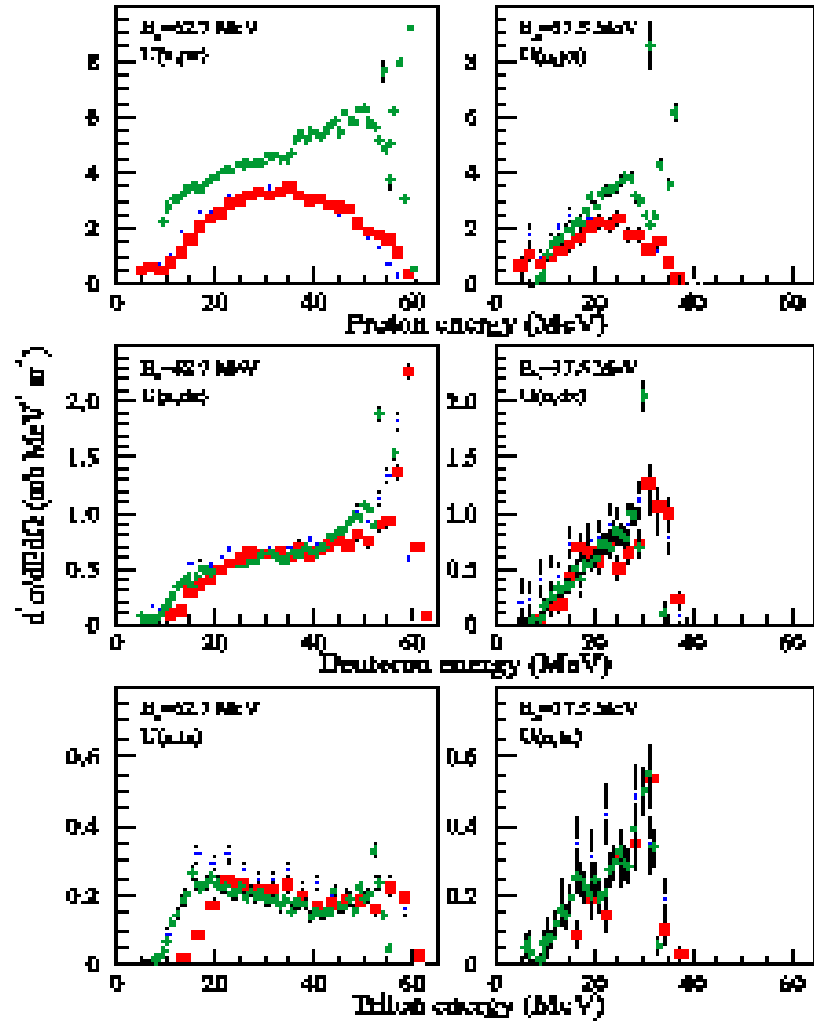

HINDAS

High- and Intermediate-energy Nuclear
Data for Accelerator-driven Systems

Studies of spallation reactions above 200 MeV

Karl-Heinz Schmidt, GSI Darmstadt

Abstract: Nuclear data of spallation reactions above 200 MeV, needed for the design of the ADS, are scarce. Experiments with proton beams in the appropriate energy regime have been made at SATURNE (Saclay) and COSY (Jülich) to obtain detailed data on light charged-particle and neutron production. Nuclide identification in-flight of heavy residues requires the application of inverse kinematics and a powerful spectrometer. For this purpose, the GSI facility has been used. In addition, this experiment provides the recoil energies of the heavy residues. The data on systematic investigations of a few representative systems, which are already partly available, put important constraints on the models to be improved or developed for this energy regime. A new-generation experiment is in preparation which intends to determine the light-particle production in coincidence with the production of heavy residues. This technique will allow to better determine the characteristics of the nuclear-collision phase and of the deexcitation phase independently.

3 Work packages:

(dedicated to specific reaction channels)

- **Light charged particles** (Jülich, Saclay)
- **Neutrons** (Saclay, Bruyères, Jülich, Cern)
- **Heavy residues** (GSI, Santiago, Saclay)

Aim:

Complete understanding and modeling of spallation reactions at 200 - 2000 A MeV.

Program:

Measurements for a few targets (Fe, Pb, and U), covering all reaction channels.

Experiments performed at best-equipped European facilities.

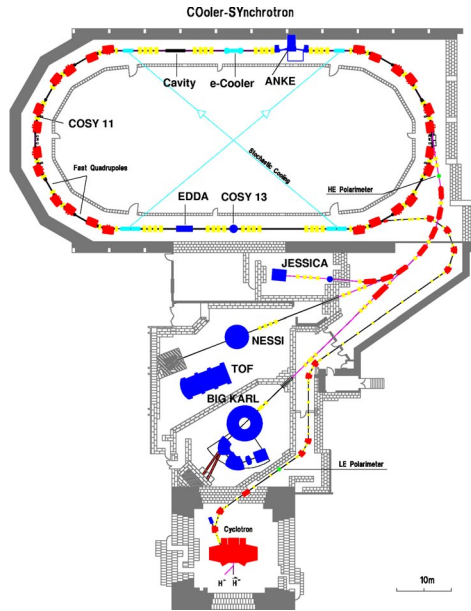

COSY, Jülich (proton beam)

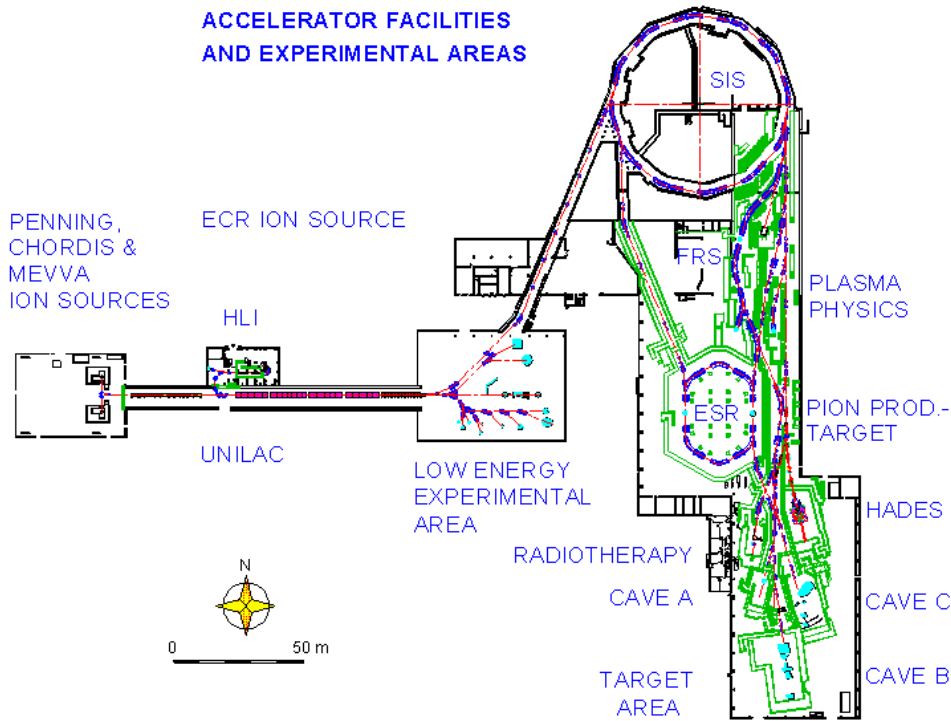

GSI, Darmstadt (heavy-ion beam, $\approx 1A\text{GeV}$)

Two different approaches

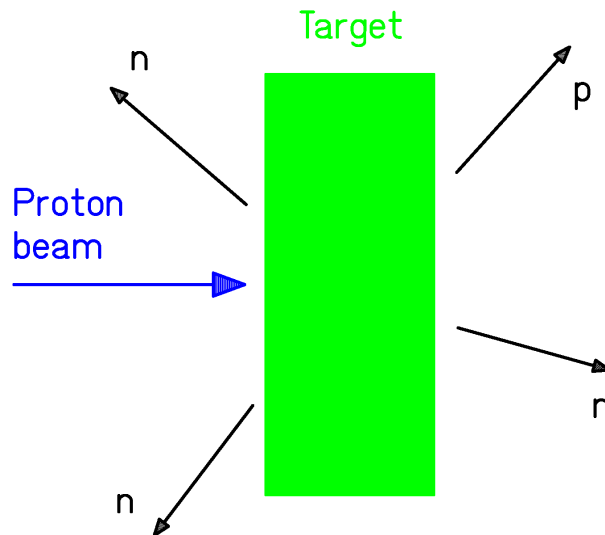

Normal kinematics

- Light particles emitted in all directions.
 - Heavy residues stick in the target.
-

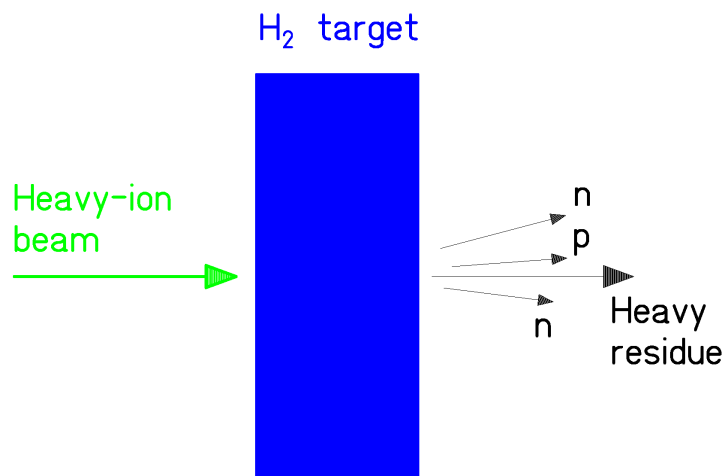

Inverse kinematics

- All reaction products in forward direction.

The BNB - BSiB Detector

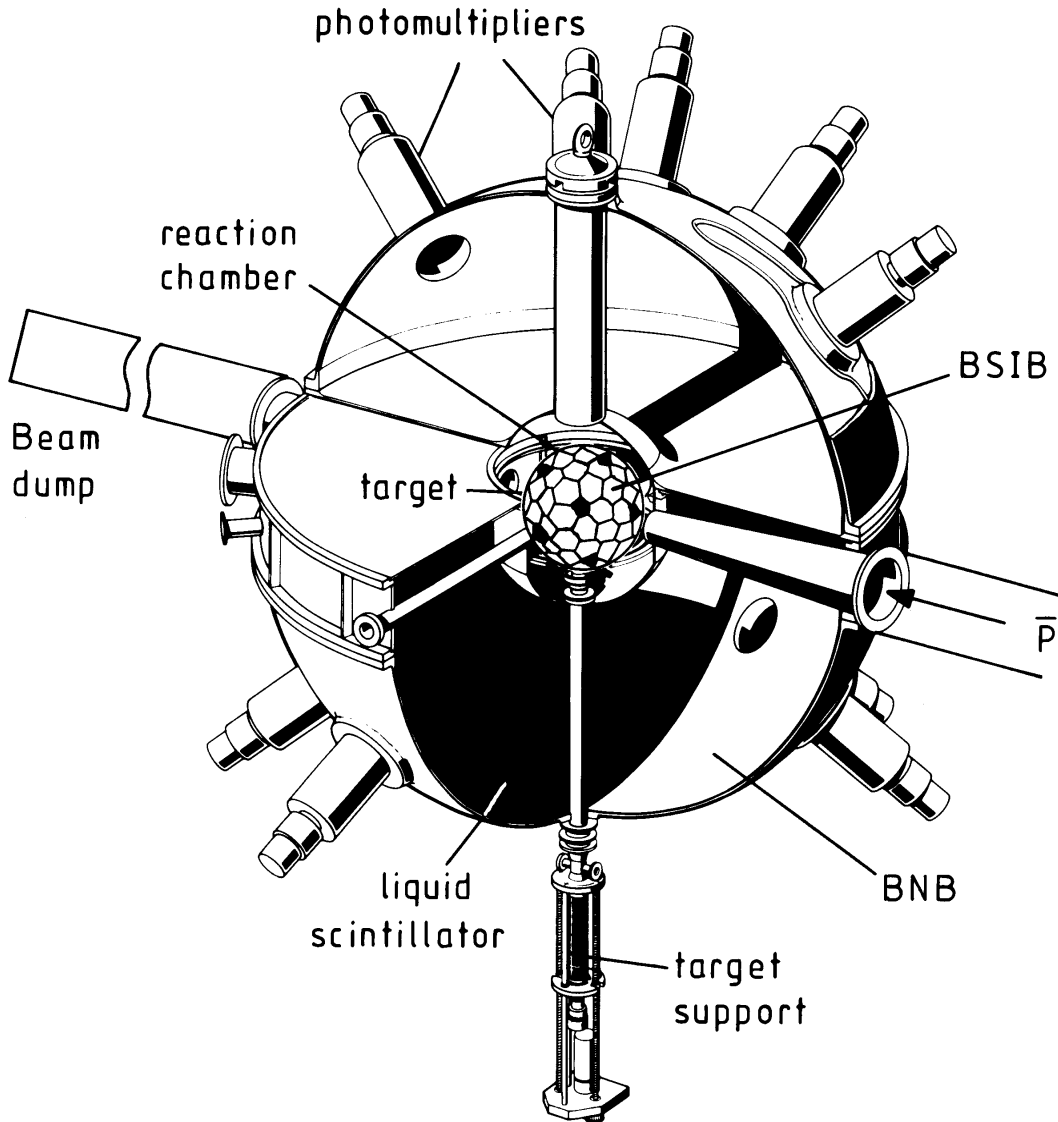

A 4π detector for neutrons and charged-particles

Production of He by 0.8 GeV protons

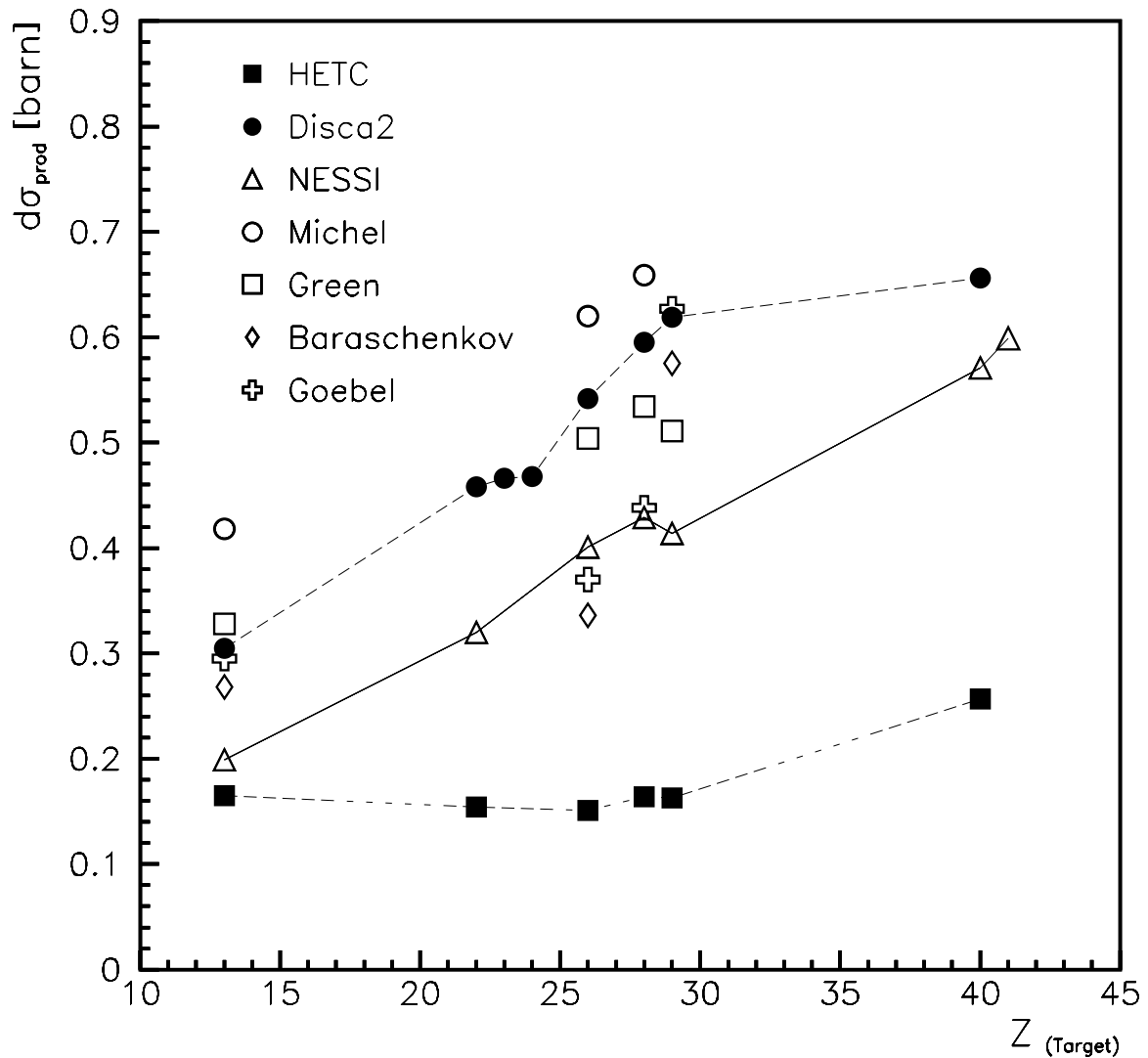

Large discrepancies between theories (■, ●) and experiments (△, ○, □, etc.).

D. Filges et al., Eur. Phys. Journ. A 11 (2001) 467

Double-differential neutron cross sections (1.2 GeV protons on lead)

2001/07/10 12.52

1200 MeV p+Pb, INCL4 + KHSV3p

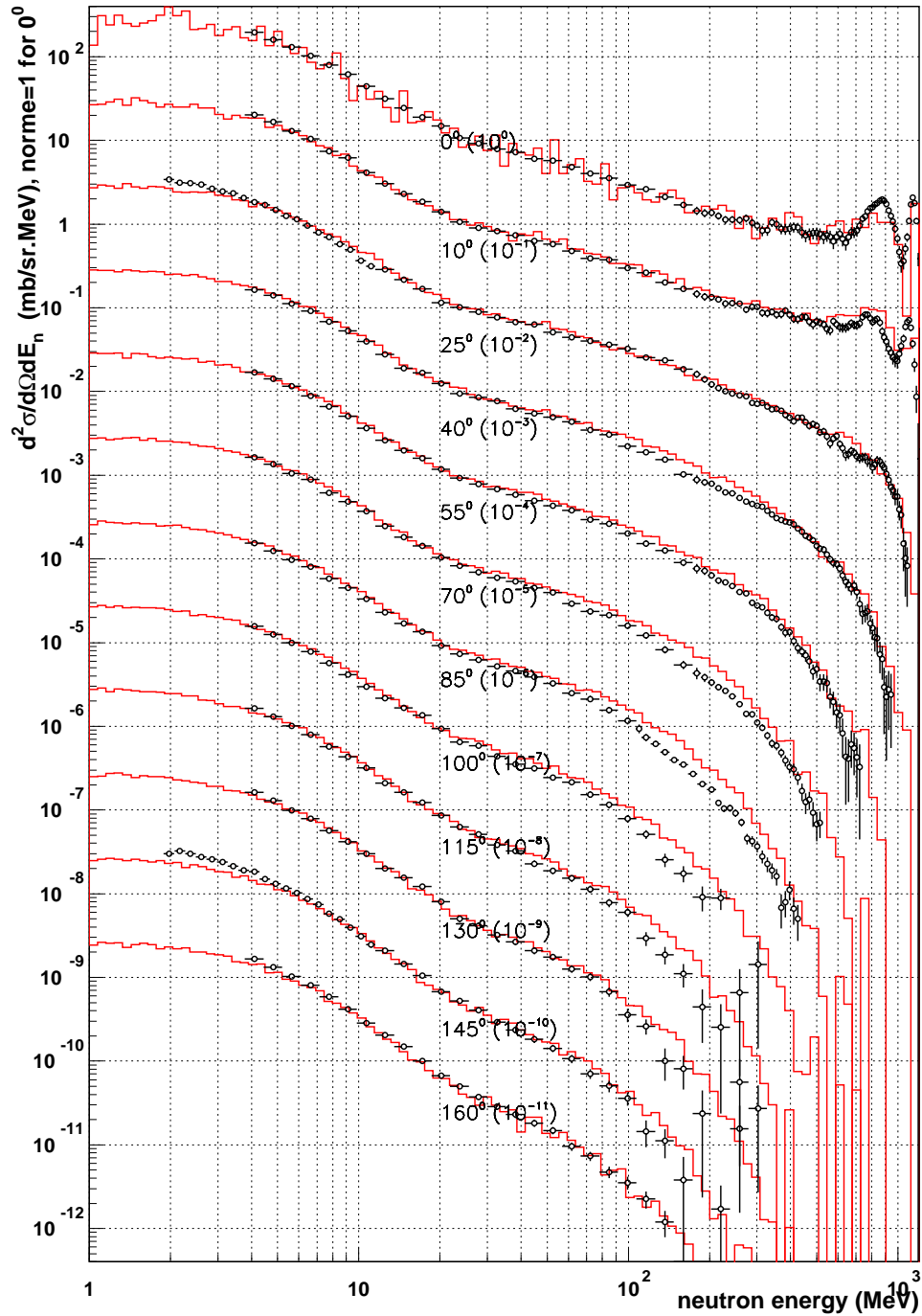

A. Boudard et al., Nucl. Phys. A663-664 (2000) 1061c

The GSI Fragment Separator

0:\RESULT5\PB-H8D\EN0\Y1ST\PUBLIC5\RUN64\HYDR

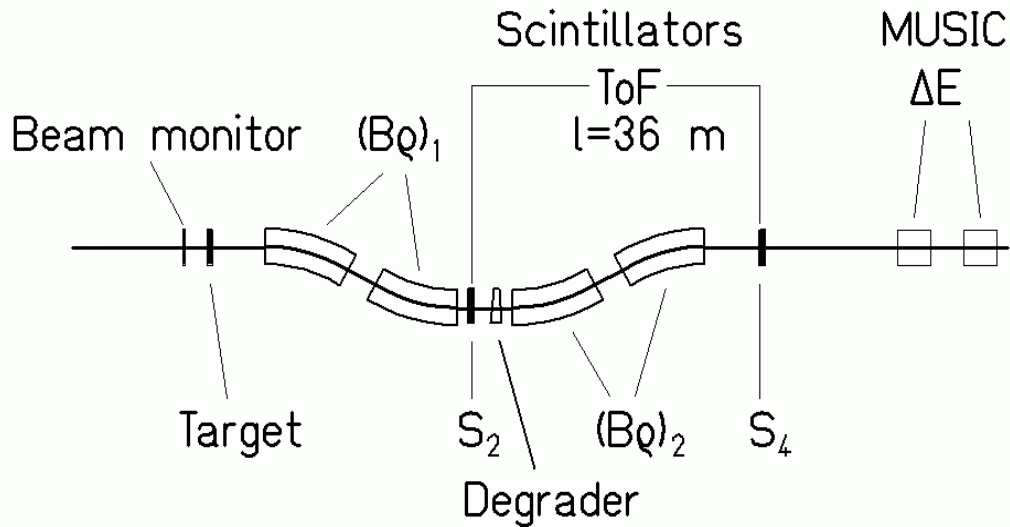

In-flight identification of heavy residues.

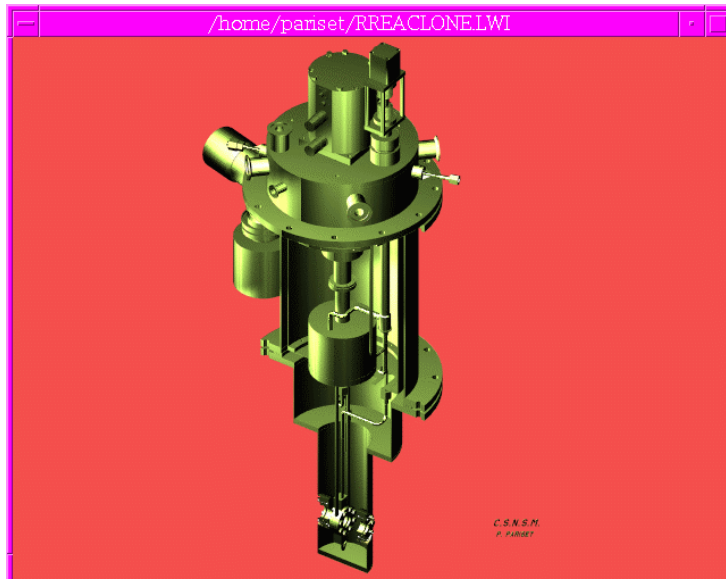

Filling:
 $H_2: 90 \text{ mg/cm}^2$

Windows:
 $Ti: 36 \text{ mg/cm}^2$

The liquid-hydrogen target (CEA Saclay).

Identification pattern ($^{208}\text{Pb} + ^1\text{H}$)

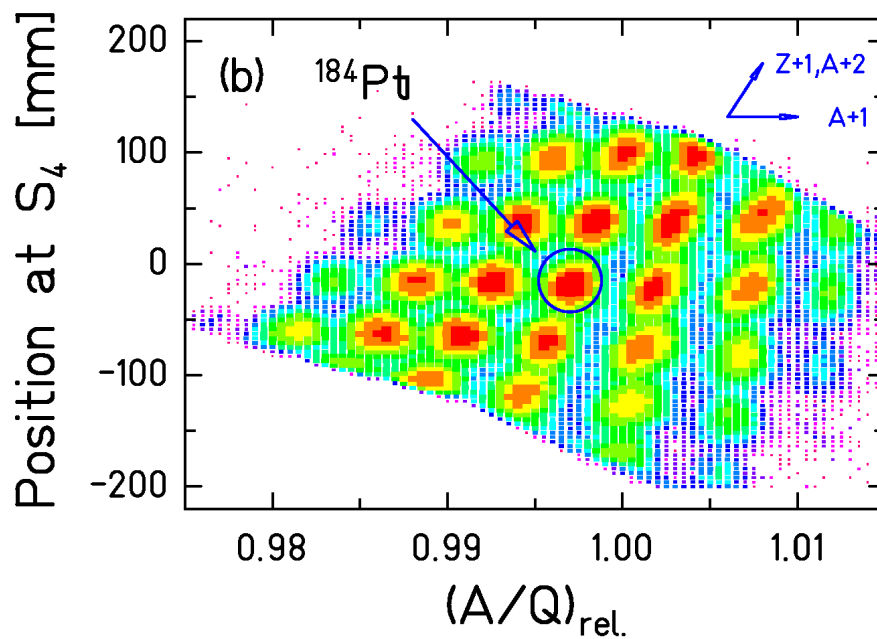
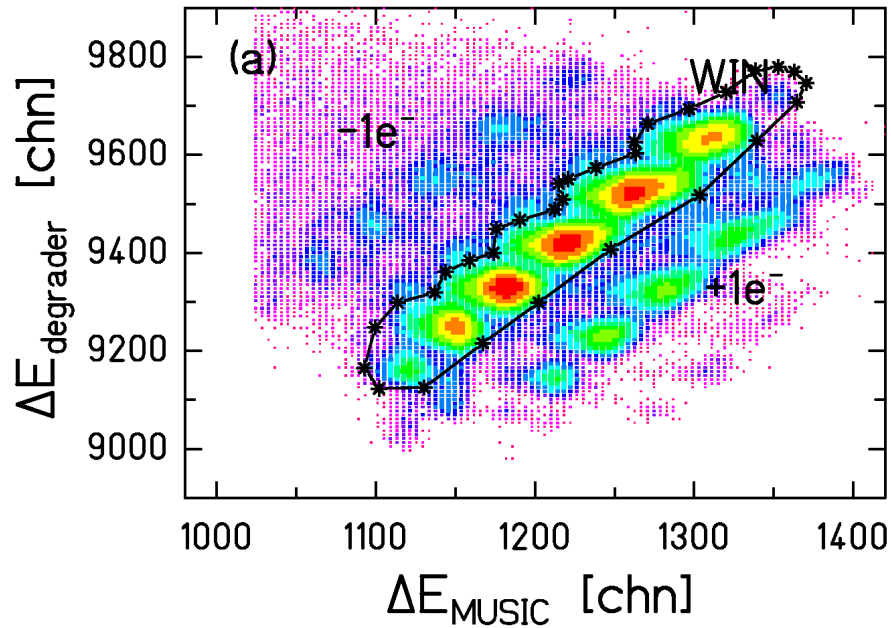

- (a) Identification of ionic charge states
- (b) Separation in A and Z

Kinematics ($^{208}\text{Pb} + ^1\text{H}$)

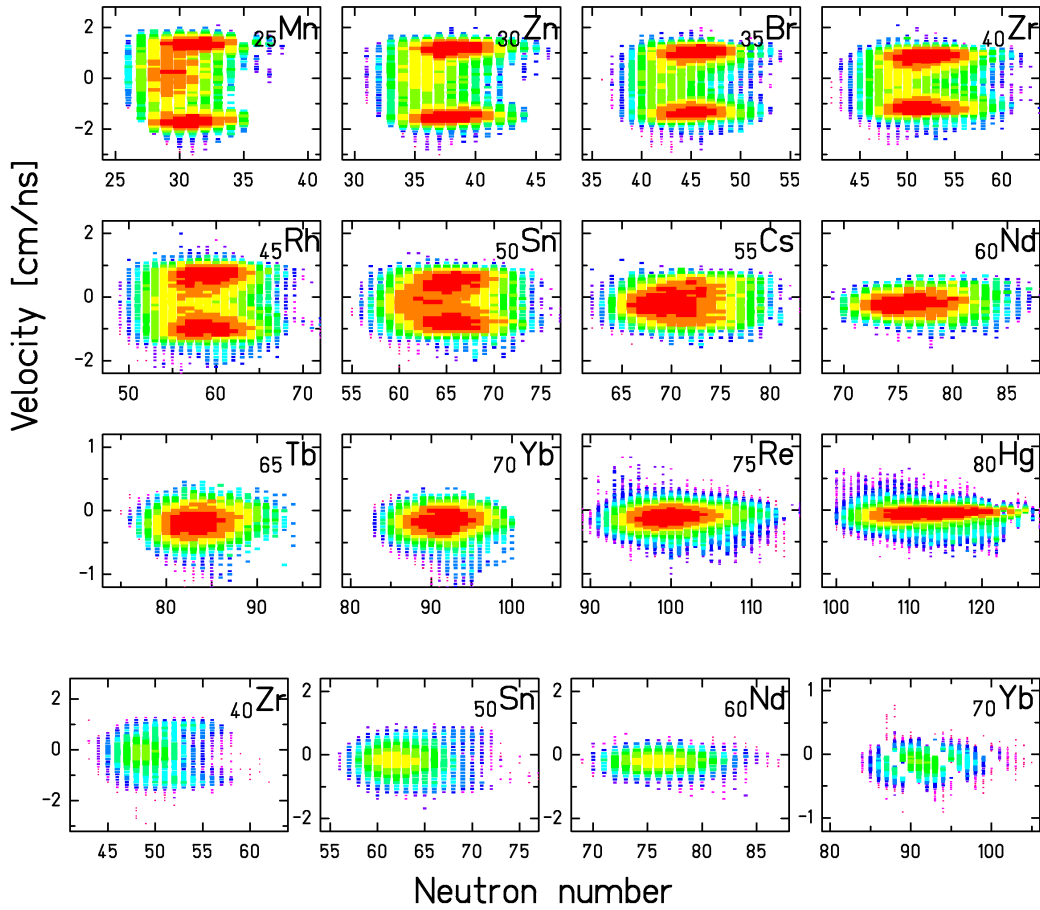

Velocity Diagram

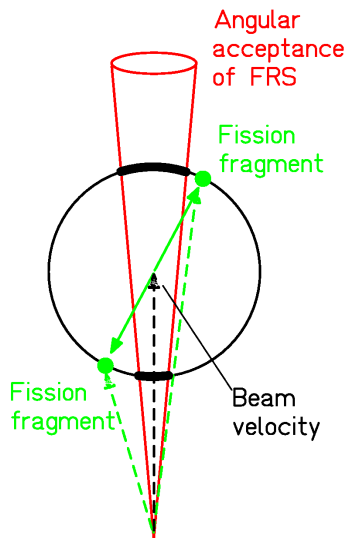

Velocity distribution of every nuclide

- ➔ Recoil energy
- ➔ Production mechanism

Sideward emission suppressed.

Production cross sections

^{208}Pb (1 A GeV) + proton

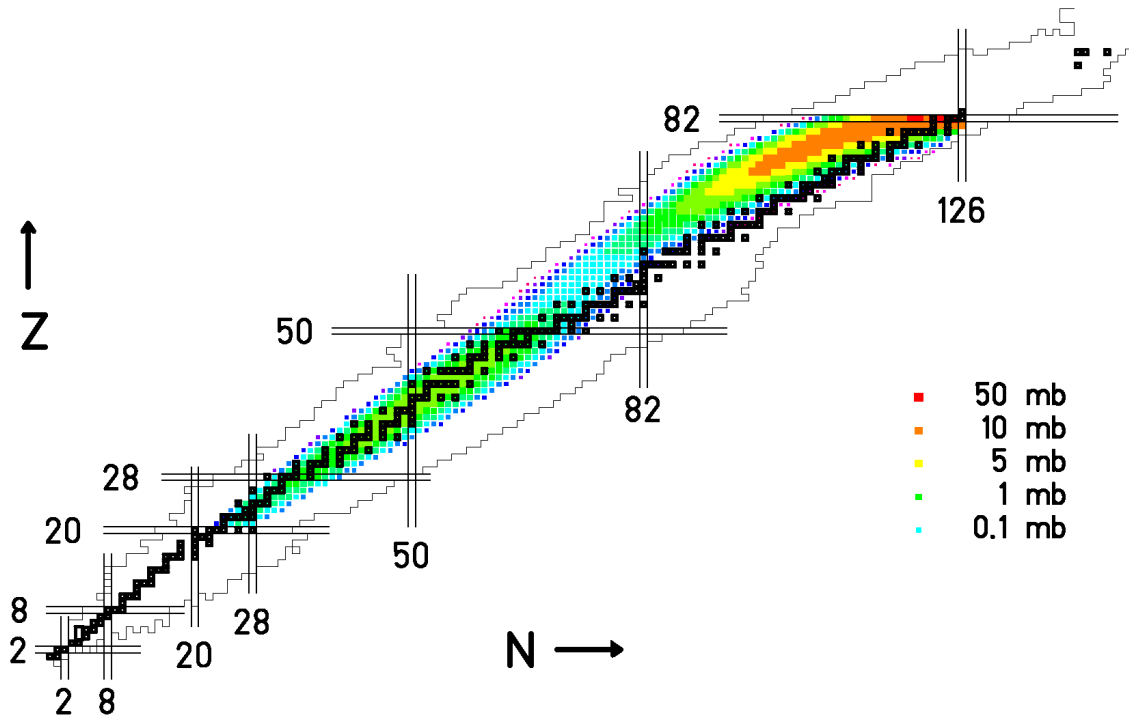

**For the first time:
Full coverage of all nuclides produced by
fragmentation and fission.
(Uncertainties $\leq 10\%$ in most cases.)**

T. Enqvist et al., Nucl. Phys. A 686 (2001) 481-524

Production cross sections

^{208}Pb (1 A GeV) + proton

(Some isotopic sequences)

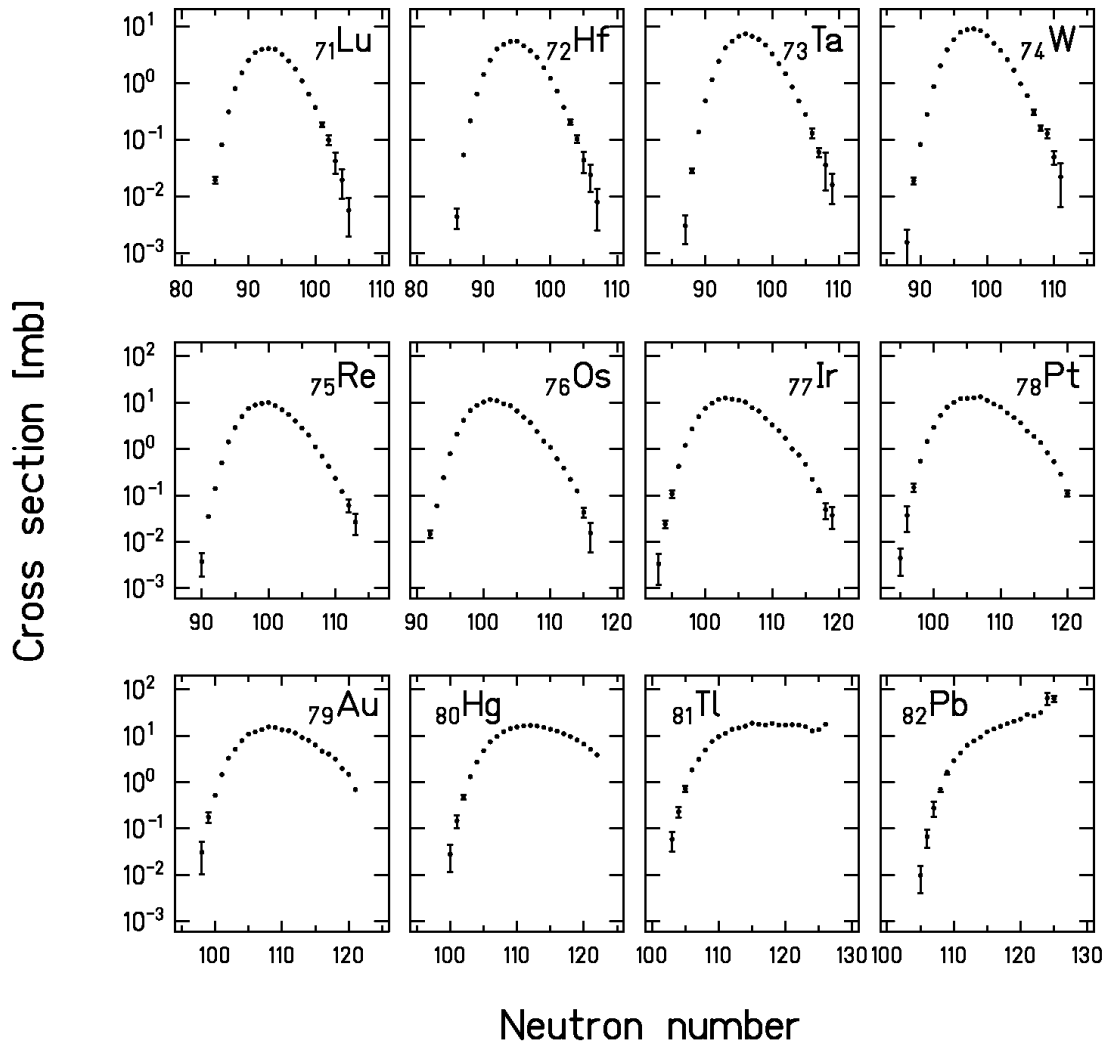

T. Enqvist et al., Nucl. Phys. A 686 (2001) 481-524

Production cross sections

^{208}Pb (1 A GeV) + deuteron

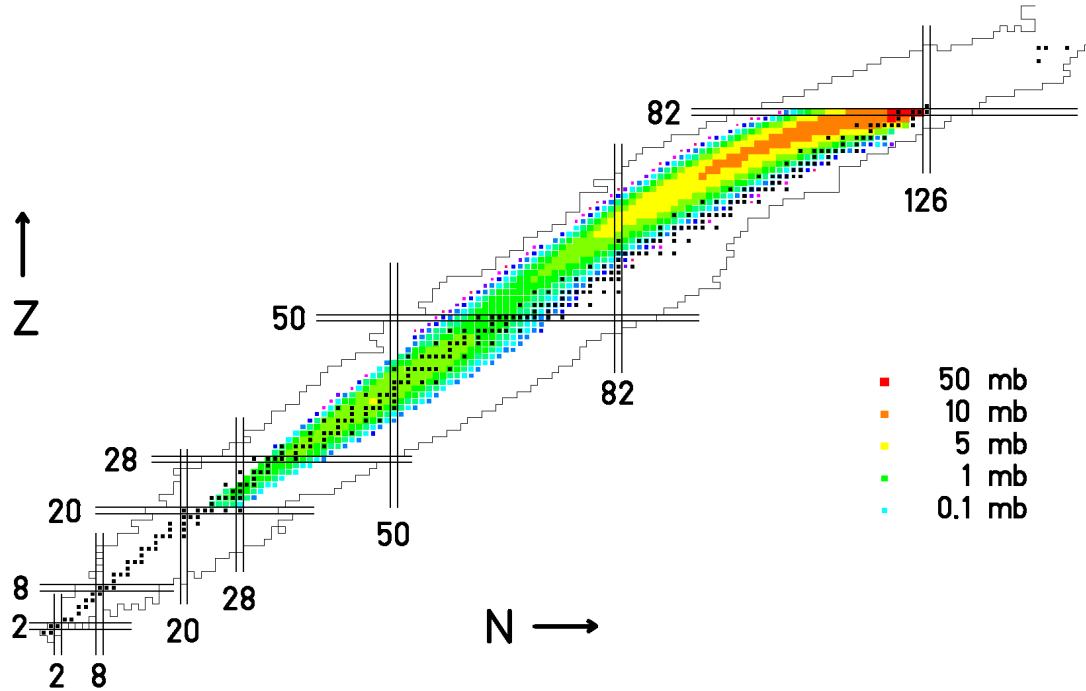

T. Enqvist et al., Nucl. Phys. A, in print

Data evaluation in progress for:

^{238}U (1 A GeV) + proton

^{238}U (1 A GeV) + deuteron

Element Distributions

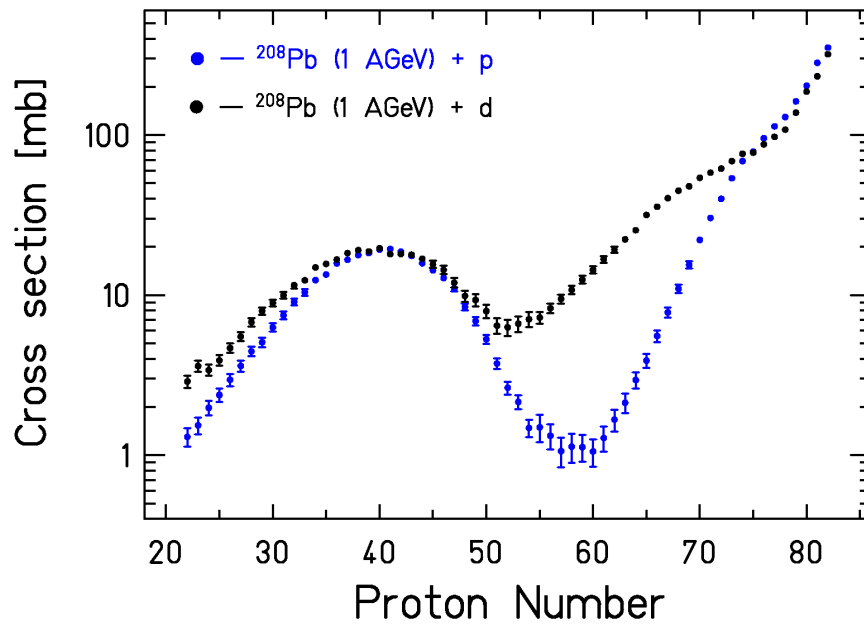

Mass Distributions

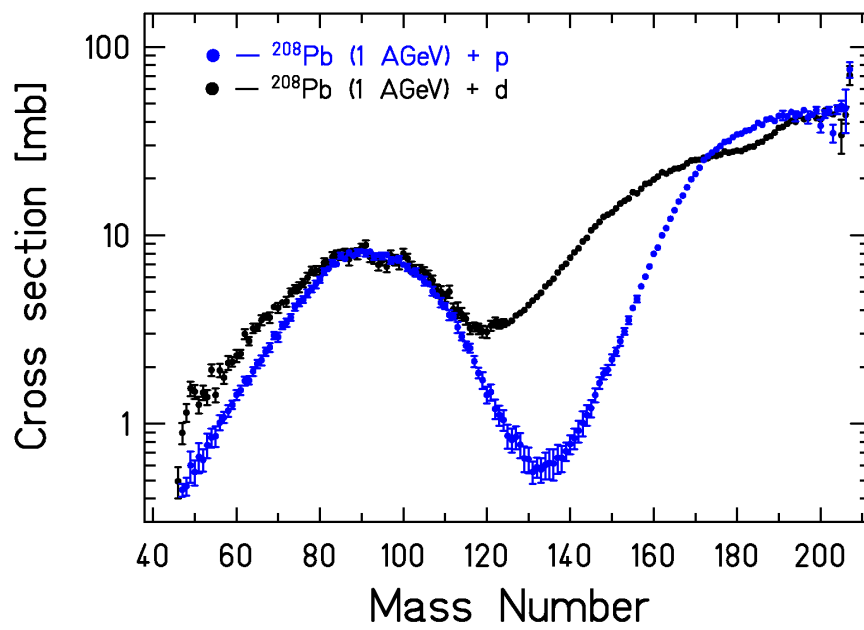

Recoil velocities

Average Longitudinal Momentum

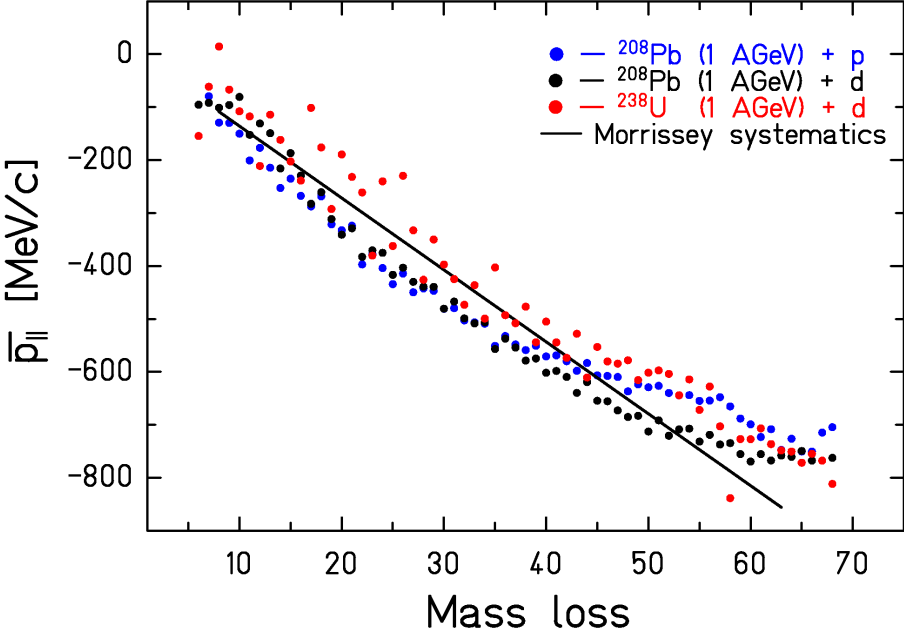

Average Momentum Width

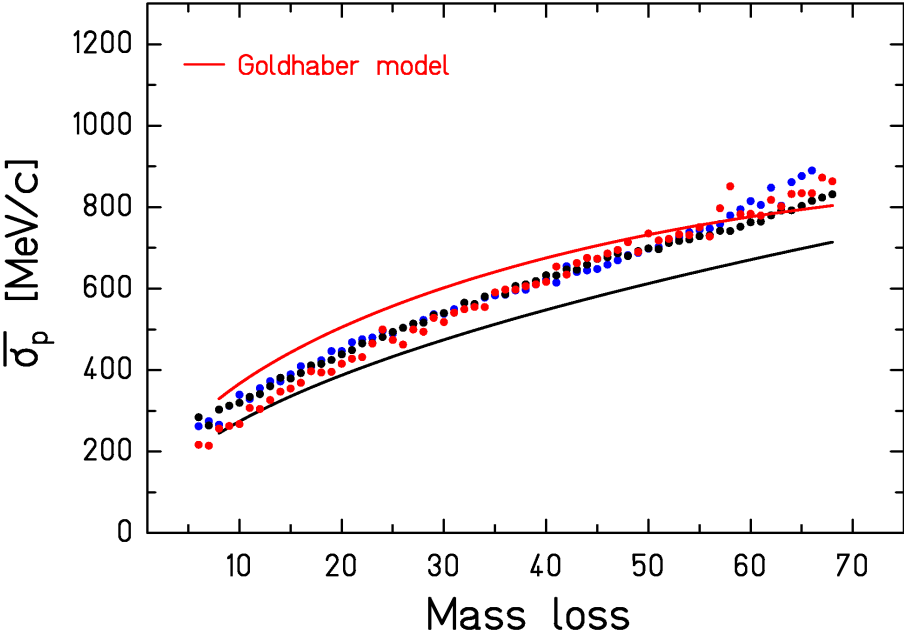

Preparation of 2nd generation experiment

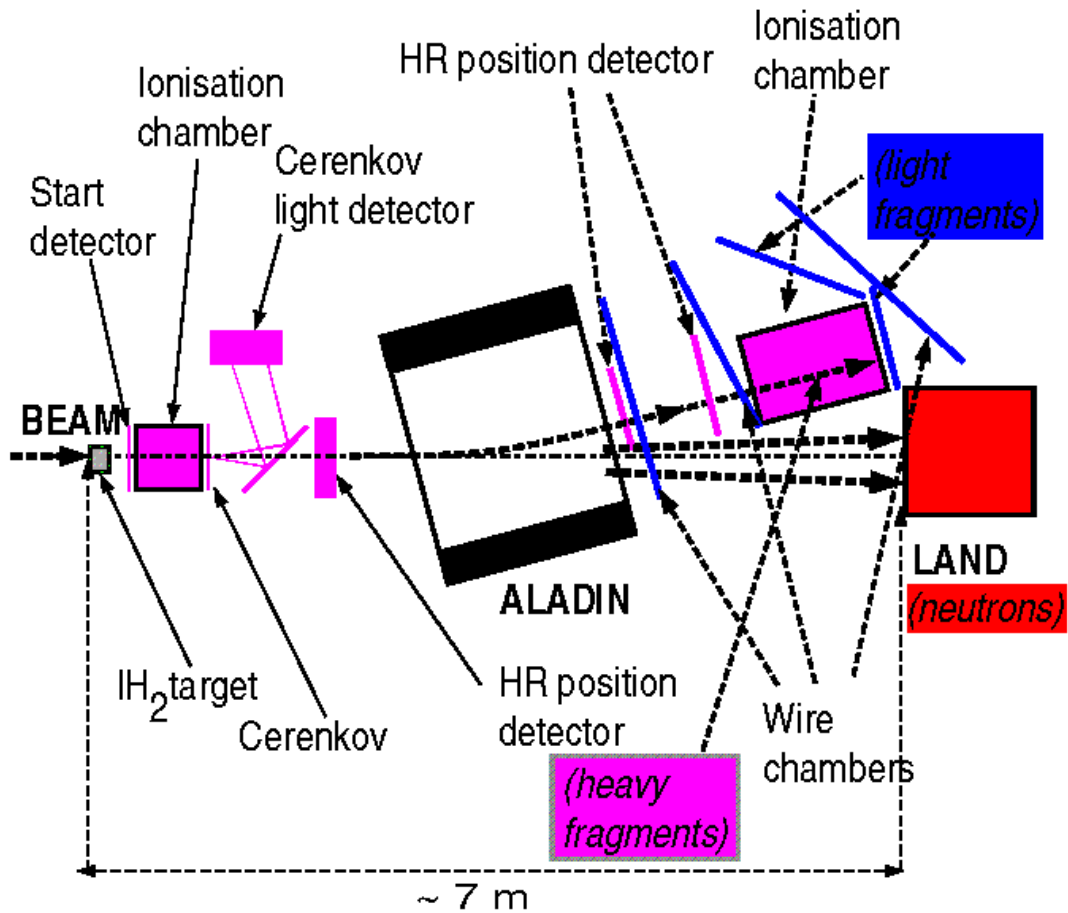

Measurement of residues in coincidence with neutrons and light charged particles (Saclay, GSI, München, Orsay, Bordeaux, Santiago)

Summary

Experimental goal:

Full coverage of yields and velocities of

- light charged particles
- neutrons
- heavy residues

for a few systems.

Status:

- Most complete set of relevant data measured.
- First results published.
- 2nd generation experiment in preparation.

New information on critical topics:

- Energy deposit in INC phase.
- Thermal instability of nuclei.
- Barriers of charged particles.
- Dissipative hindrance of fission.

An excellent basis for improved nuclear models.

Theoretical program of the HINDAS project*

J. Cugnon, University of Liege†

10th December 2001

- 1 Introduction and general presentation**
- 2 From 0 to 200 MeV**
- 3 From 200 MeV to 2 GeV**
- 4 Conclusion**

*BASTRA meeting, CERN, Dec 5, 2001

†J.Cugnon@ulg.ac.be

1. Introduction

- **From 0 to 200 MeV (WP7)**
 - Regime: Quantum scattering
 - *TALYS*: optical model, direct, pre-equilibrium, fission and statistical models; predicts all reaction cross-sections; results in ENDF
 - TUL model to predict multi-direct reactions
 - DYWAN: quasi-particle model in a wavelet basis
- **From 200 MeV to 2 GeV (WP8)**
 - Regime: Quasi-classical multiple scattering
 - INCL4 Liège INC model +KHS evaporation model; predictions of all reaction cross-sections; direct implementation in high-energy transport codes
- **Confrontation to high quality data**
- **Contribution to elaboration of transport codes (HERMES, LAHET, MCNPX)**
- **Quantities for ADS: activation, radiation damage, gas production,...**

2. 0 -> 200 MeV*

10th December 2001

1 TALYS

- ▷ Developed by NRG-Petten and CEA-Bruyeres-le-Chatel
- ▷ A continuous smooth description of the reaction mechanisms (ALICE, GNASH, ...)
- ▷ Direct, compound, preequilibrium, fission
- ▷ Automatic reference to nuclear data
- ▷ Or various phenomenological models. Ex: Gilbert-Cameron or HFB microscopic level density

2 Fission model

- ▷ T-dependent Brosa model
- ▷ Hill-Wheeler probability on effective barrier
- ▷ Fitted on recent data

*BASTRA meeting, CERN, Dec 5, 2001

WP7: Nuclear data libraries and related theory

- Integration of all nuclear models for $\text{few keV} < E < 200 \text{ MeV}$ in one nuclear reaction code: TALYS.
- TALYS predicts
 - Total and partial cross sections, energy spectra, angular distributions, double-differential spectra and an exact modelling of exclusive cross sections and spectra.
 - Excitation functions for residual nuclide production, including isomeric cross sections.
 - Fission and gamma production.
- Theoretical analysis of all HINDAS measurements below 200 MeV.
- Optical model development.
- New proton and neutron data libraries for selected materials up to 200 MeV.

TALYS: CALCULATIONAL SCHEME

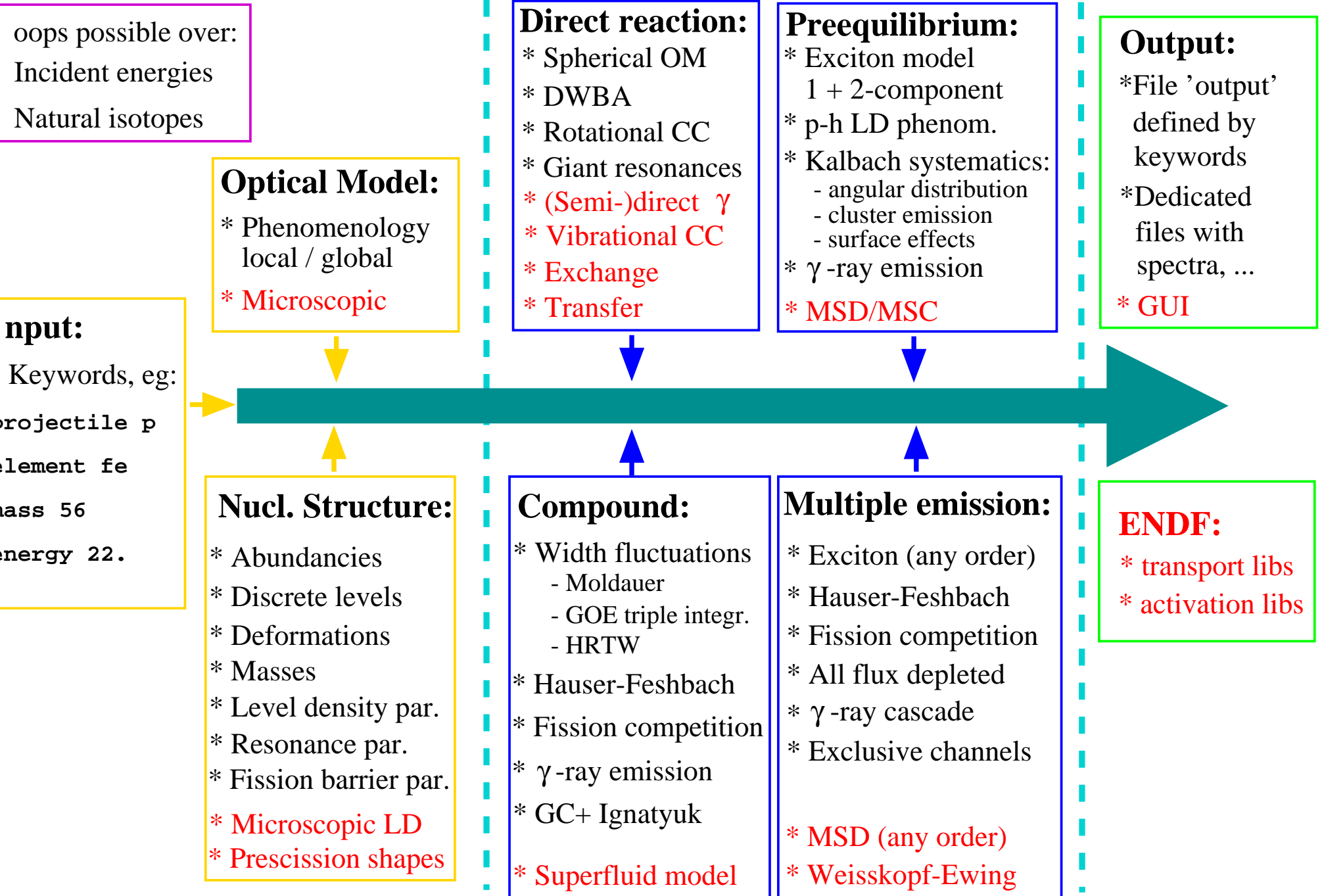

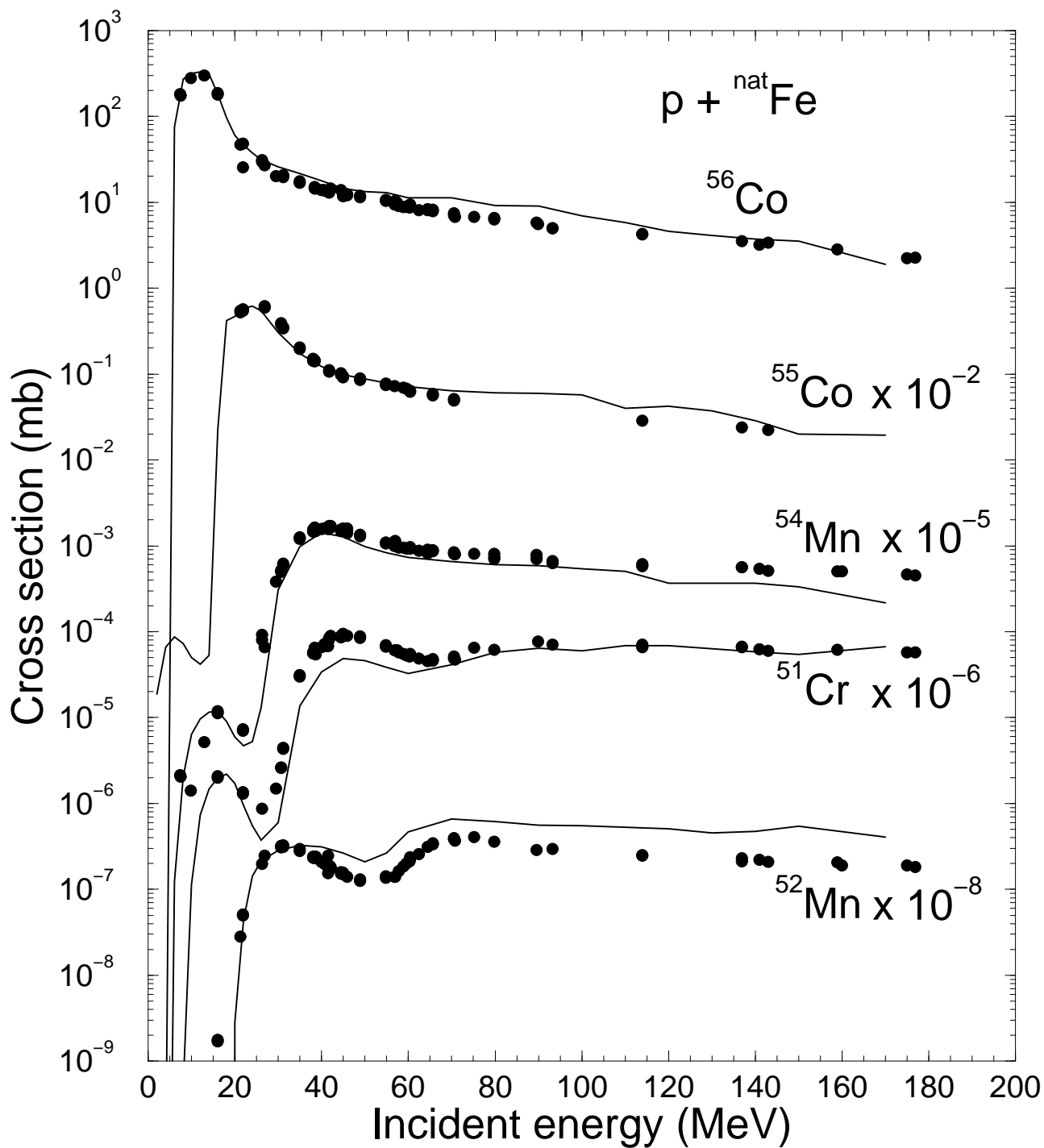

Fission at Intermediate Energies

- Competition with particle emission (multi-chance fission):

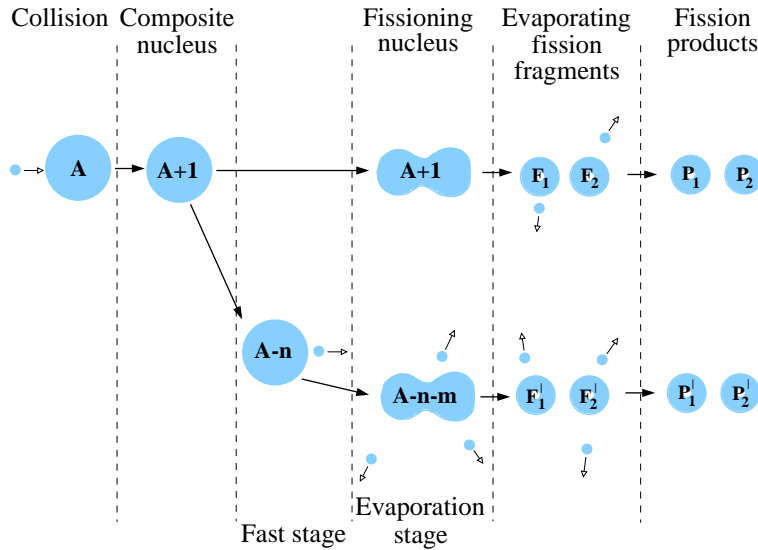

ALICE-91

$$\longrightarrow \sigma_F(A, Z, E^*)$$

- Change of fission fragment properties with E^* :

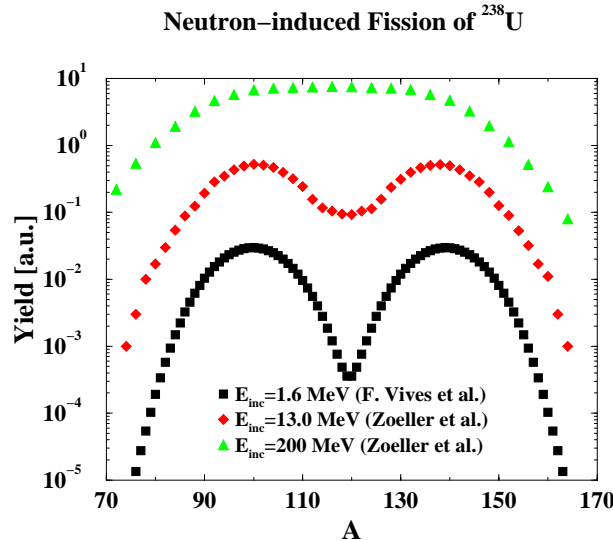

T-dependent Brosa model

$$\longrightarrow Y(A_{FF}, A, Z, E^*)$$

- Predictions of mass yields:

$$Y(A_{FF}) = \sum_{A,Z,E^*} (\sigma_F(A, Z, E^*) Y(A_{FF}, A, Z, E^*))$$

ALICE-91+BROSA I

Pre-neutron emission mass yields: subactinides

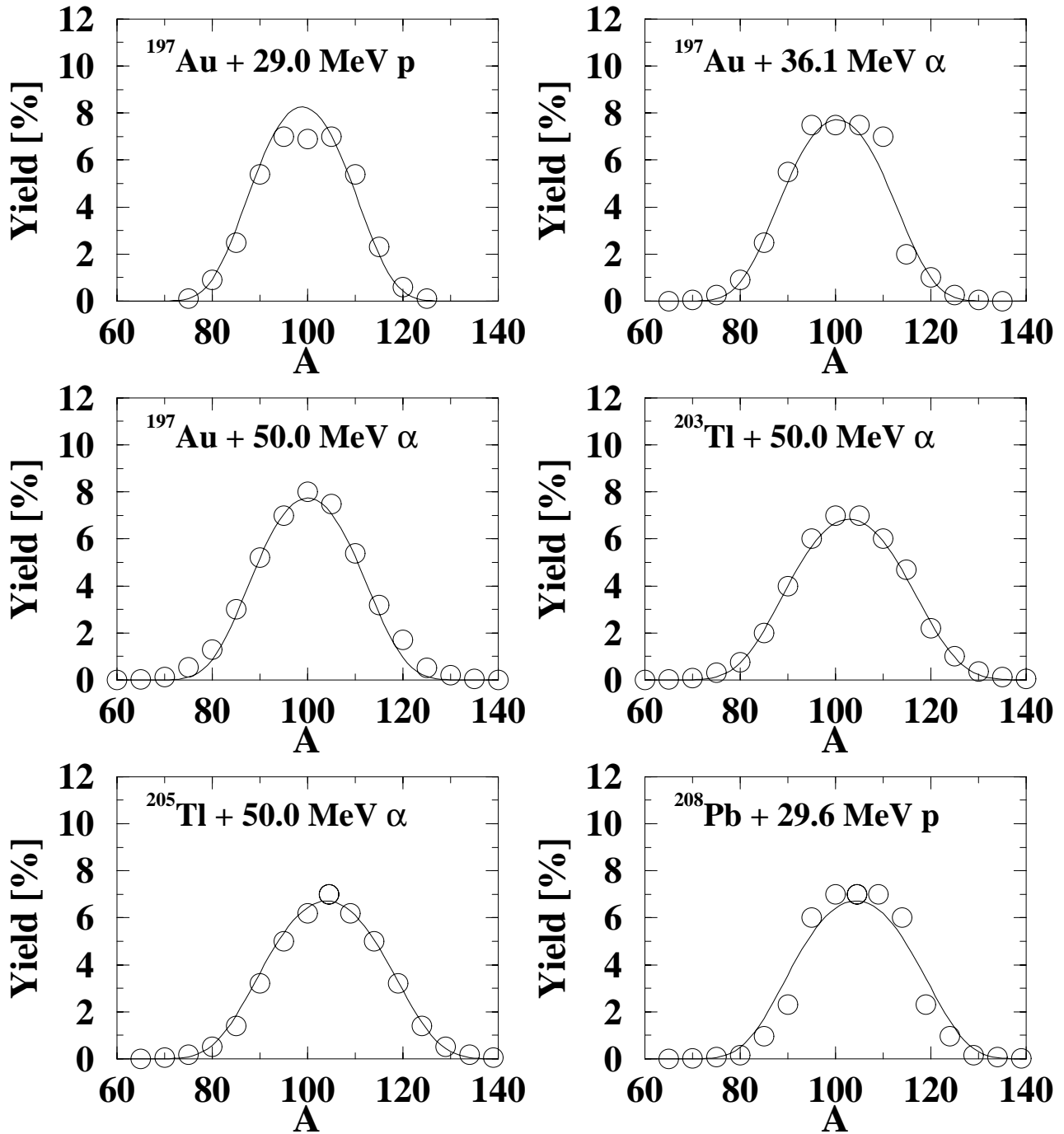

Itkis *et al* Sov. J. Nucl. Phys. 41 (1985) 544, Sov. J. Nucl. Phys. 47 (1988) 4.

ALICE-91+BROSA II

Pre-neutron emission mass yields: $n + {}^{238}\text{U}$

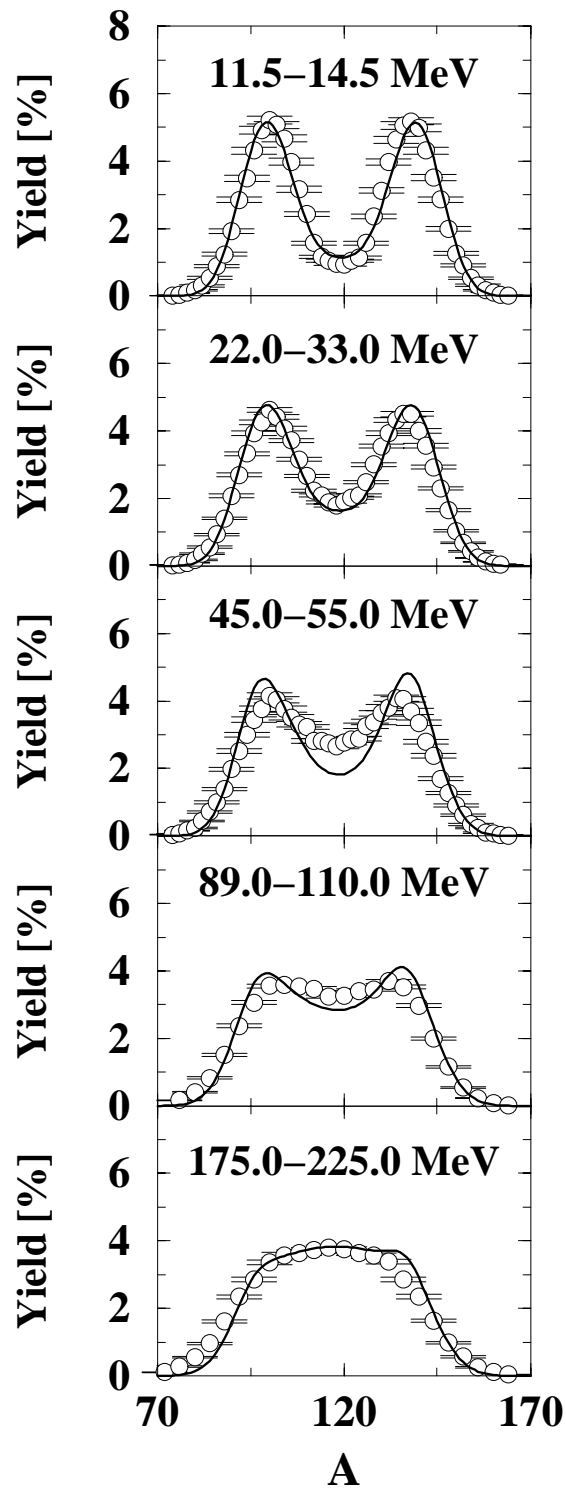

Zöller *et al*, PhD thesis, TH Darmstadt, (1995).

3. 200 MeV \rightarrow 2GeV*

10th December 2001

1 INCL4

- ▷ Improved version of the Liege INC model
- ▷ A quasi-classical multiple scattering model
- ▷ improvements: smooth surface, consistent Pauli blocking, delta dynamics, light incident ions, angular momentum,...
- ▷ Time structure

2 KHS evaporation model:

- ▷ Weisskopf model for n, p , alpha evaporation with barriers fitted on isotopic distributions, Gilbert-Cameron-Ignatyuk level density ($\rightarrow A/11$ at high excitation energy)
- ▷ Fission model: Hill-Wheeler formula, l- and T- dependent barriers, mass splitting based on energy landscape, viscosity effects through a fission delay recipe

*BASTRA meeting, CERN, Dec 5, 2001

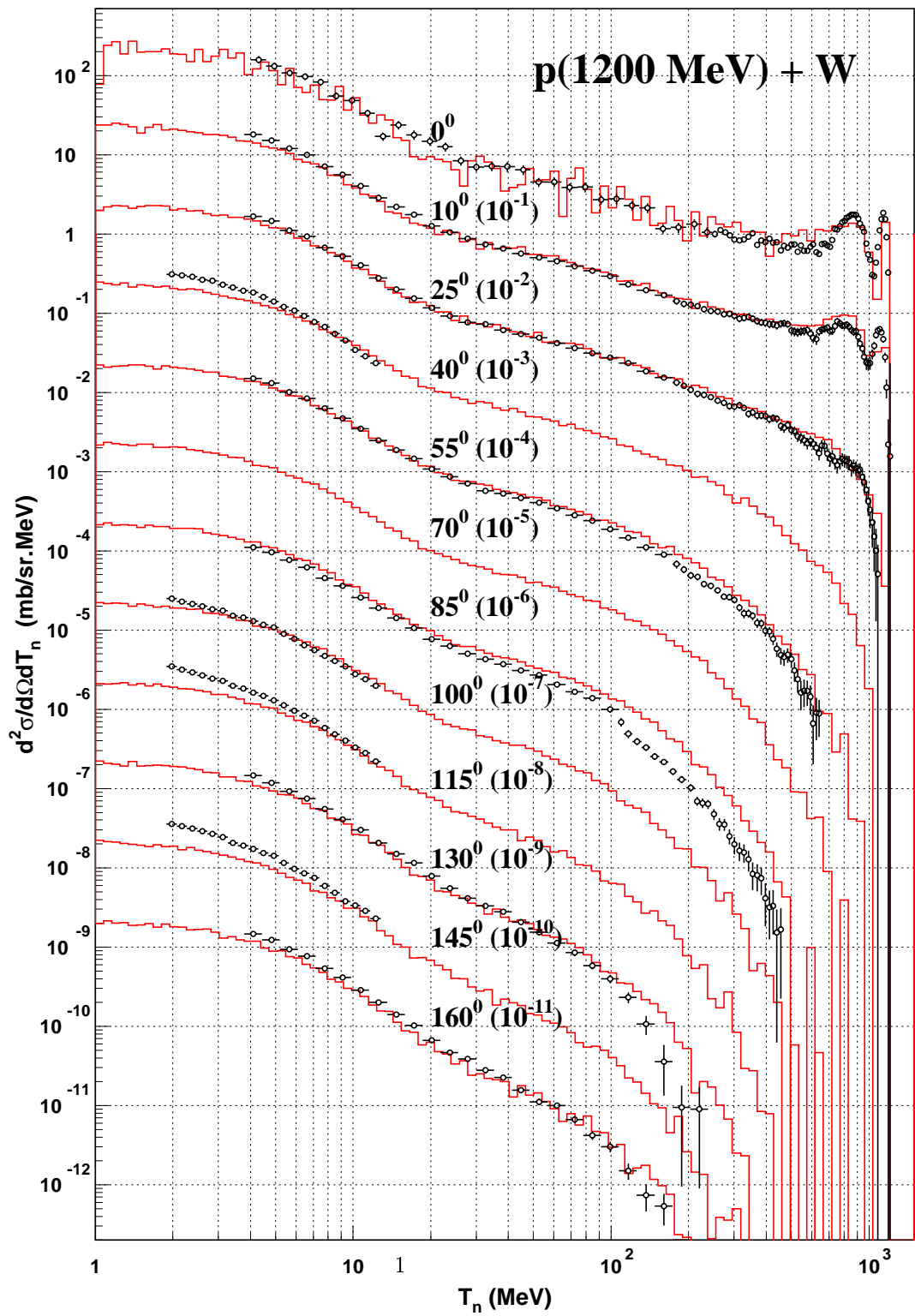

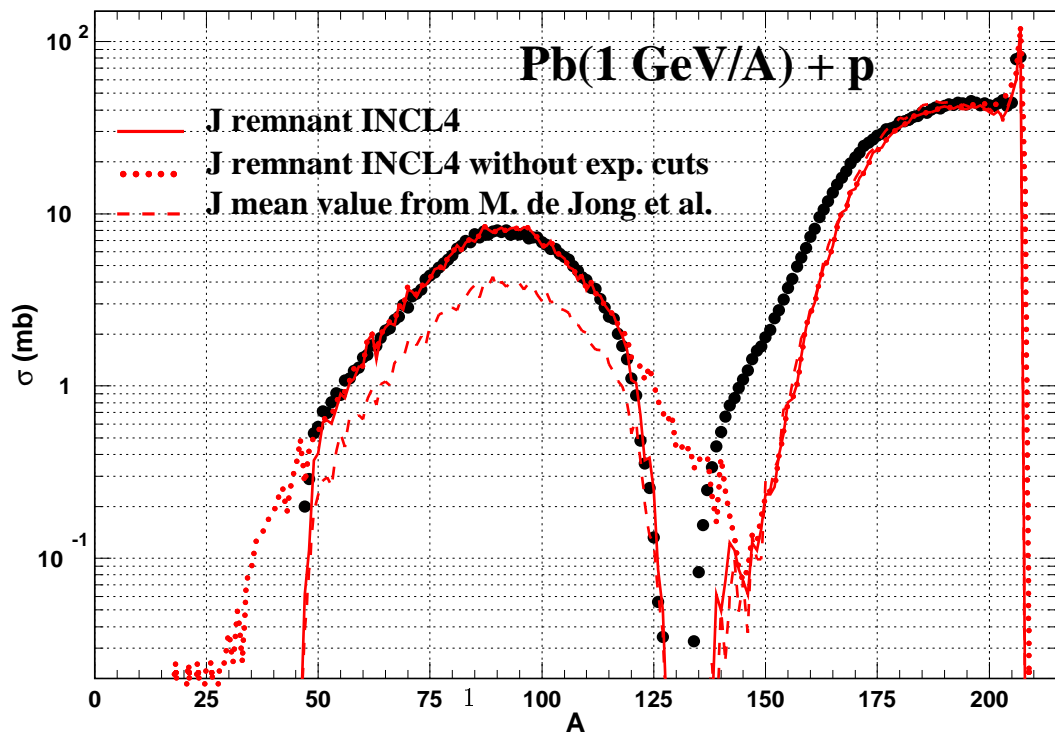
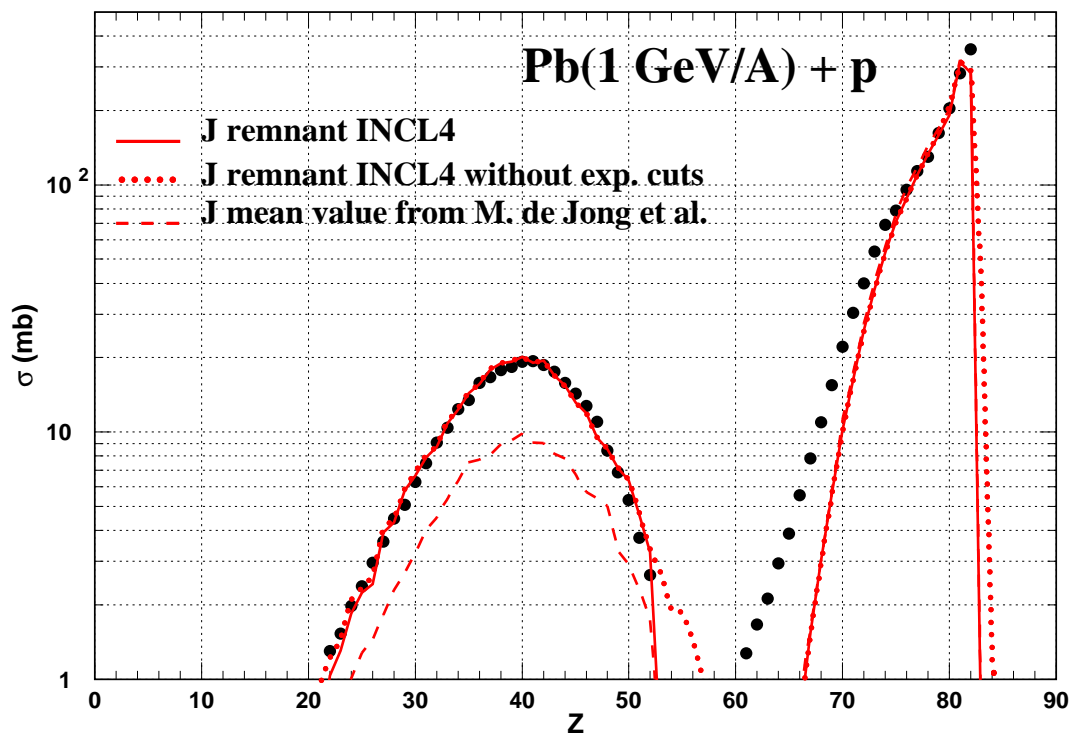

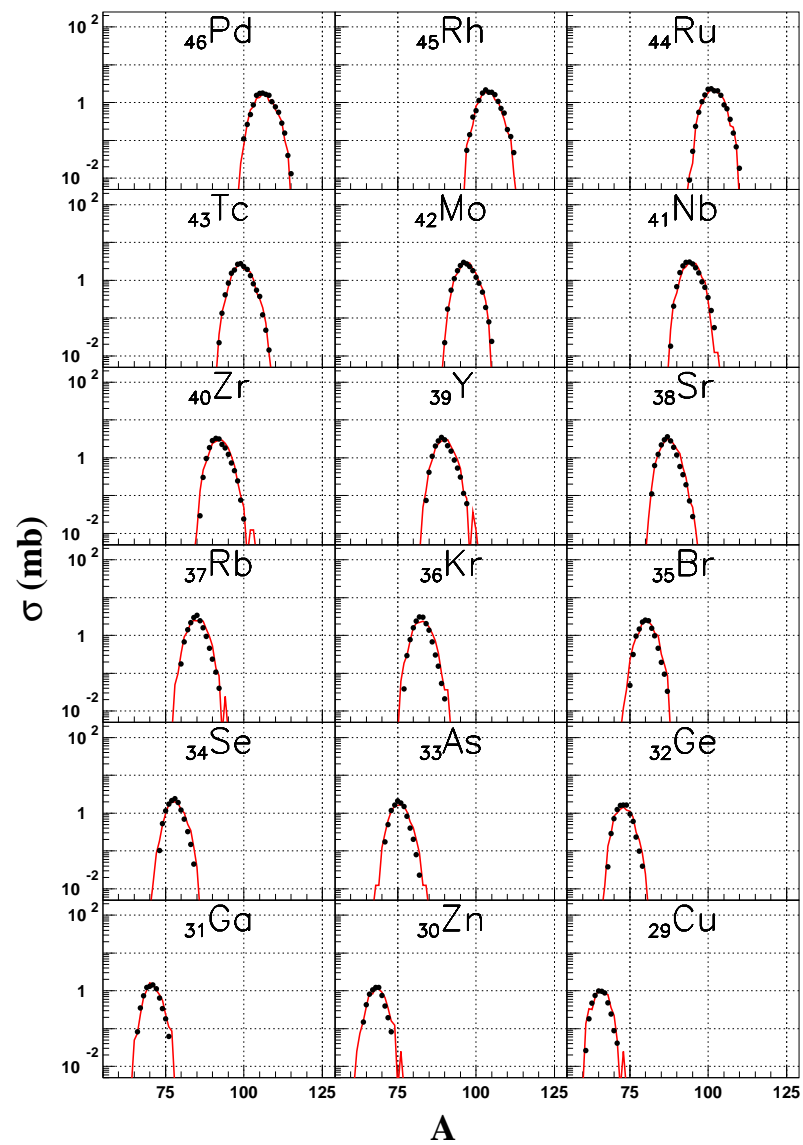
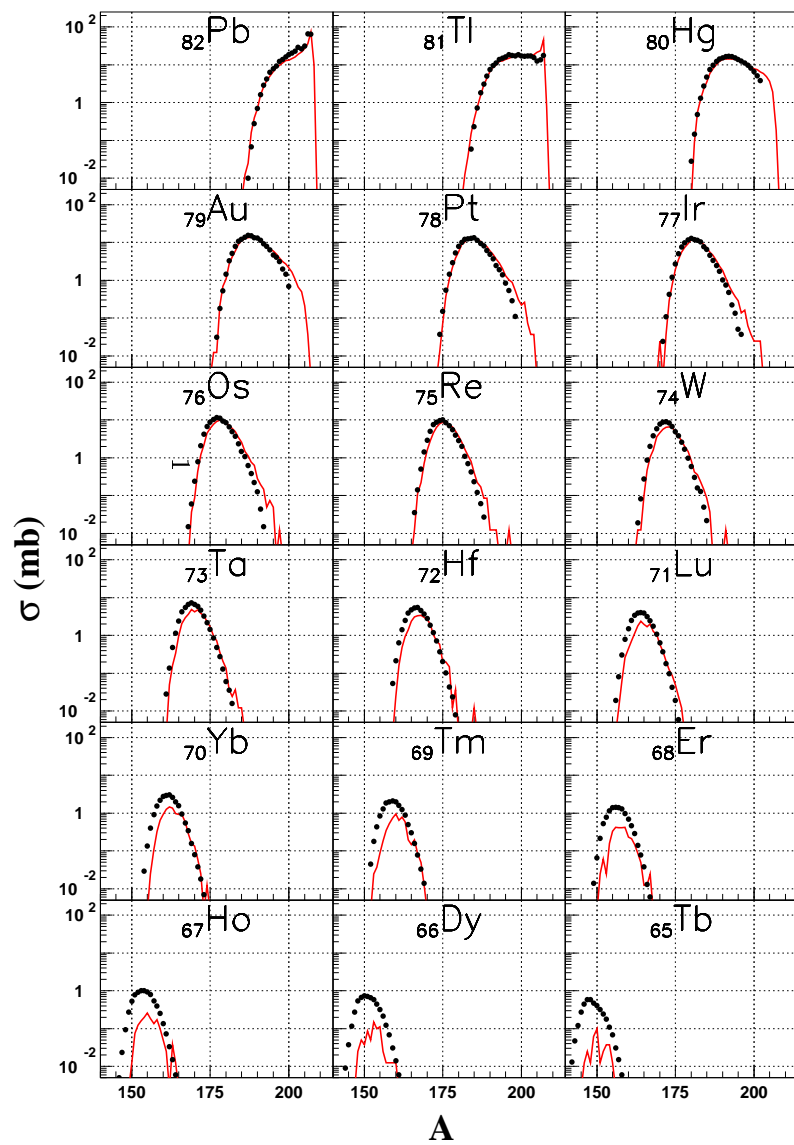

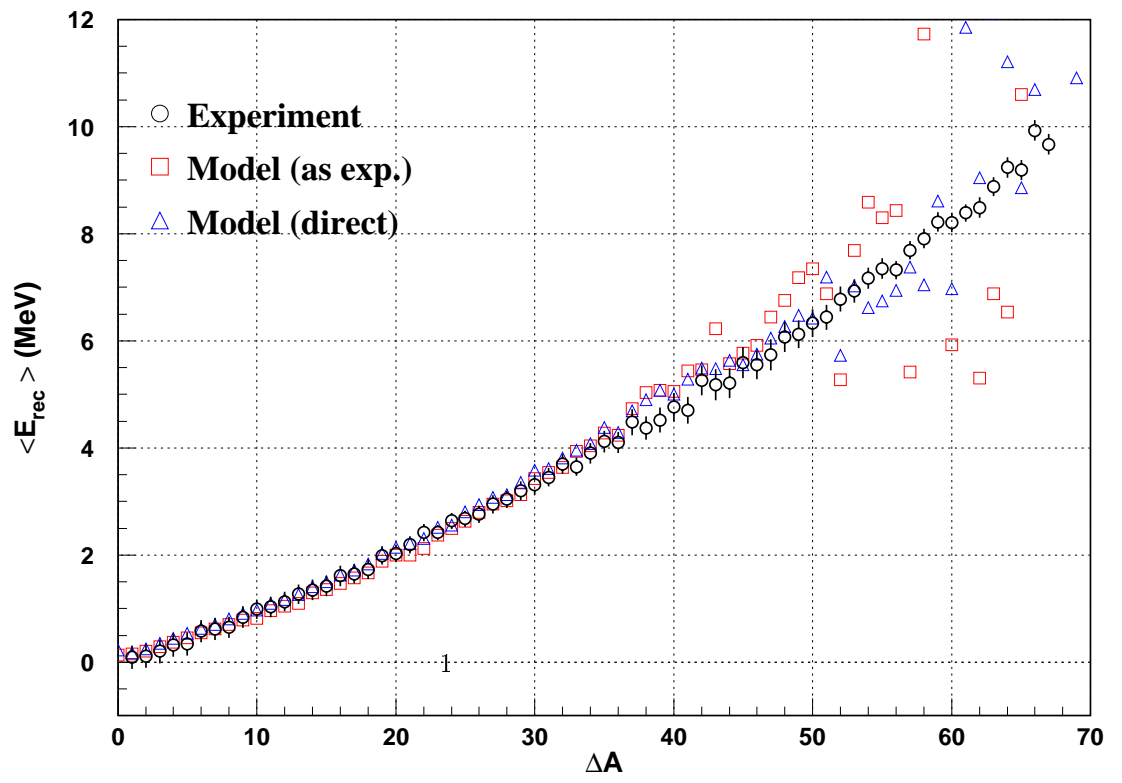
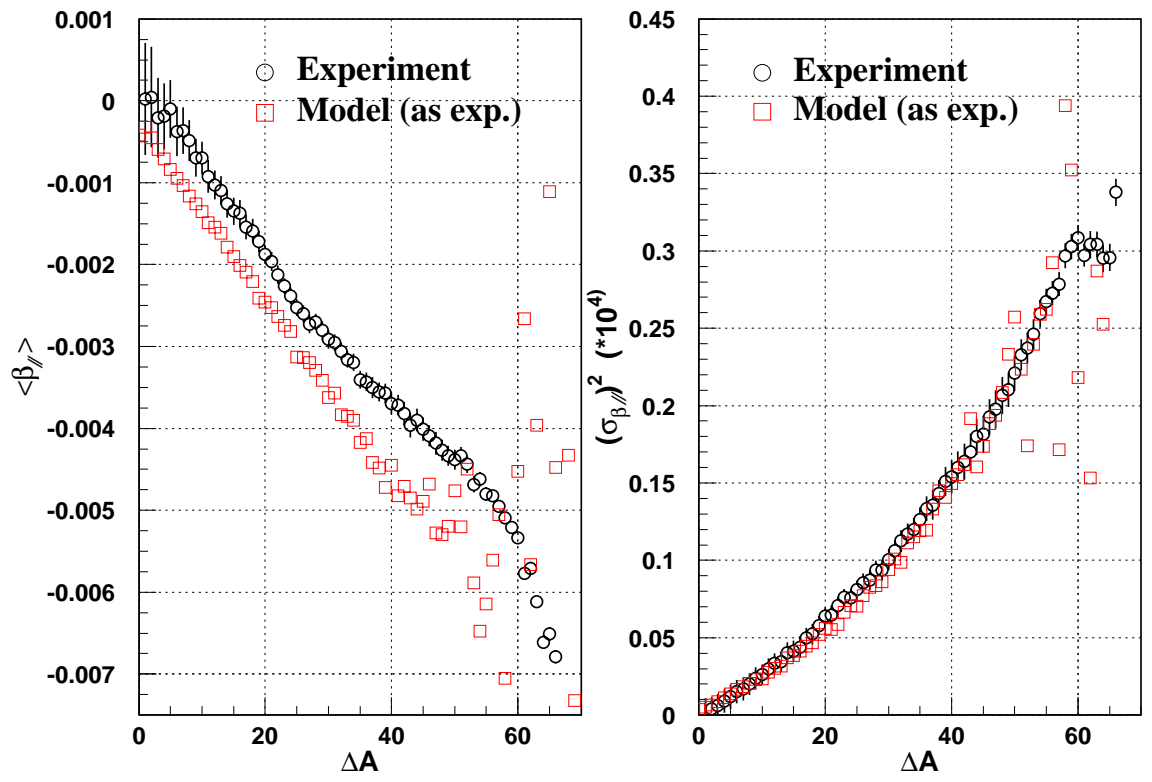

4. Conclusion*

10th December 2001

- 1 Theoretical work is well in progress: it will be implemented in transport codes before the end of HINDAS
- 2 Did we reach the required precision for ADS applications? Sensitivity studies are necessary
- 3 Contributions are from many people in HINDAS, more particularly from:
 - ▷ WP7: *A.Koning, E. Randstrom, F. Sebille*
 - ▷ WP8: *J. Cugnon, S. Leray, A. Boudard, C. Volant, K.-H. Schmidt, F. Goldenbaum, D. Filges*

*BASTRA meeting, CERN, Dec 5, 2001

The n_TOF Collaboration



The n_TOF-ND-ADS project





n_TOF Collaboration

◆ Austria

- *Atominstytut der österreichischen Universitäten, Wien*
- *Institut Isotopenforschung & Kernphysik, Univ. Wien*
- *Fachhochschule Wr. Neustadt*

◆ Bulgaria

- *State Energy and Energy Resources Agency, Sofia,*
- *Institute Nuclear Res. & Energy, Bulgarian Academy*
- *Central Lab. Mechatronics & Instr., Bulgarian Academy*

◆ CERN

- *SL Division, Geneva*

◆ France

- *IN2P3, CENBG, Bordeaux*
- *IN2P3, IPN, Orsay*
- *IN2P3, IReS, Strasbourg*
- *Commissariat à l'Energie Atomique/DSM/DAPNIA/SPhN*

◆ Germany

- *FZK Karlsruhe GmbH, Institut für Kernphysik*

◆ Greece, Astro-Particle Consortium

- *Nuclear Physics Lab. of the Univ. of Athens*
- *Nuclear Physics Dept. of the Technical Univ. of Athens*
- *Nuclear Physics Institute, NCSR "Demokritos", Athens*
- *Nuclear Physics Lab. of the Univ. of Ioannina*
- *Nuclear Physics Lab. of the Univ. of Thessaloniki*
- *Nuclear Physics Dept. of the Univ. of Thrace*

◆ Italy

- *ENEA, Applied Physics Division*
- *Laboratori Nazionali di Legnaro*
- *Instituto Nazionale di Fisica Nuclear-Bari*
- *Instituto Nazionale di Fisica Nuclear-Trieste*
- *Universita degli Studi Pavia*

◆ EC-JRC

◆ Poland

- *University of Lodz*

◆ Portugal

- *LIP-Departemento de Fisica da Universidade de Coimbra*



n_TOF Collaboration..... *continue*

◆ Russia

- JINR, Frank Laboratory of Neutron Physics, Dubna
- Institute of Physics and Power Engineering, Obninsk

◆ Spain

- CIEMAT
- CSIC – Univ. Valencia
- Universidad Politecnica de Madrid
- Universidad de Sevilla
- Universidade de Santiago de Compostela
- Universitat Politecnica de Catalunya

◆ Sweden

- Kungliga Tekniska Hogskolan, Physics Department

◆ Switzerland

- Department of Physics and Astronomy, Univ. of Basel

◆ The Netherlands

- Delft Univ. Technology, Interfaculty Reactor Institute

◆ USA

- Los Alamos National Laboratory
- Oak Ridge National Laboratory, Physics Division
- University of Notre Dame

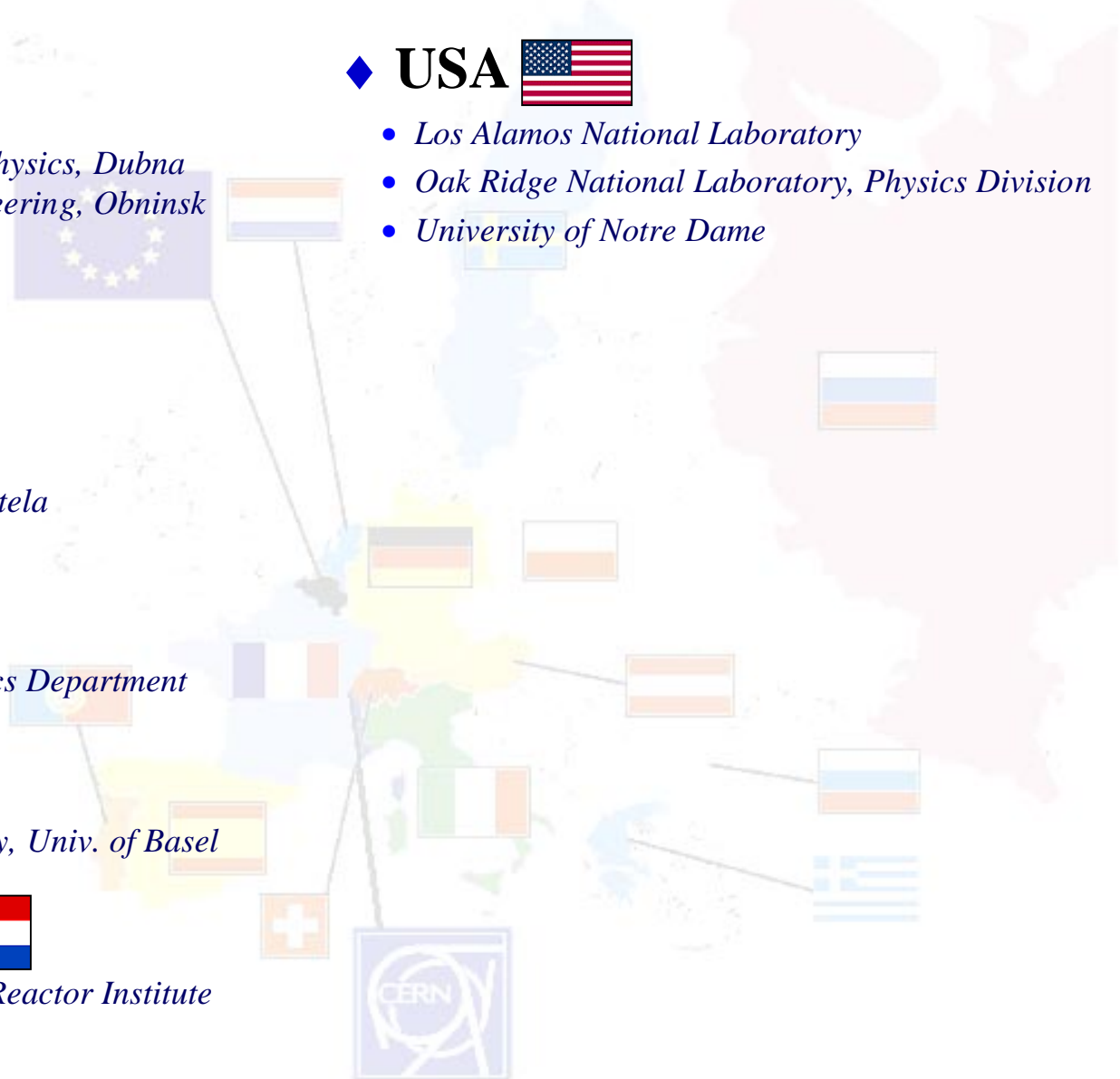



n_TOF SCIENTIFIC OBJECTIVES

The n_TOF Collaboration aims at the

- ♣ *consistent and cost effective production,*
- ♣ *formal evaluation and*
- ♣ *dissemination*

- according to international standard ways -

of **neutron induced reaction cross sections** in the

Field of Nuclear Technology & Dosimetry.

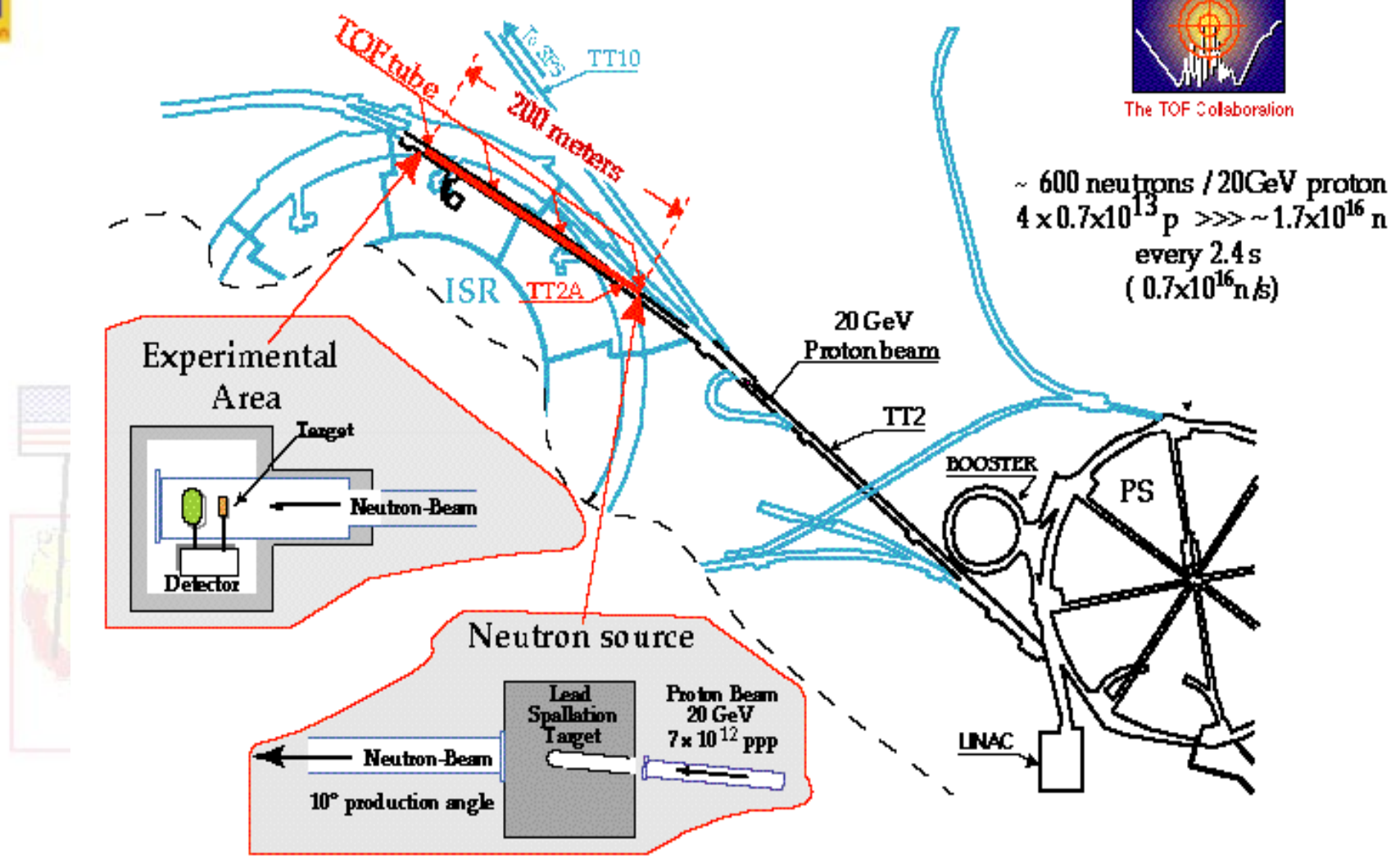

The CERN Time of Flight Facility



Lead target



Vacuum tube



2nd collimator



Experimental area

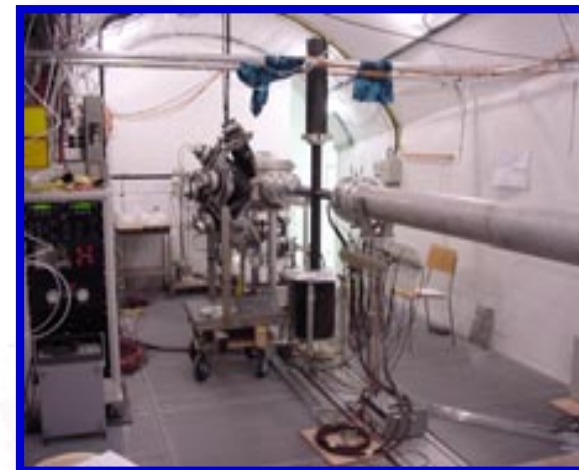

Sweeping magnet



Neutron escape line



Target container



Gas lines toward the n_TOF Exper. Area



Cupboard for the
Inflammable gases



Gas Alarm units

The Experimental Area

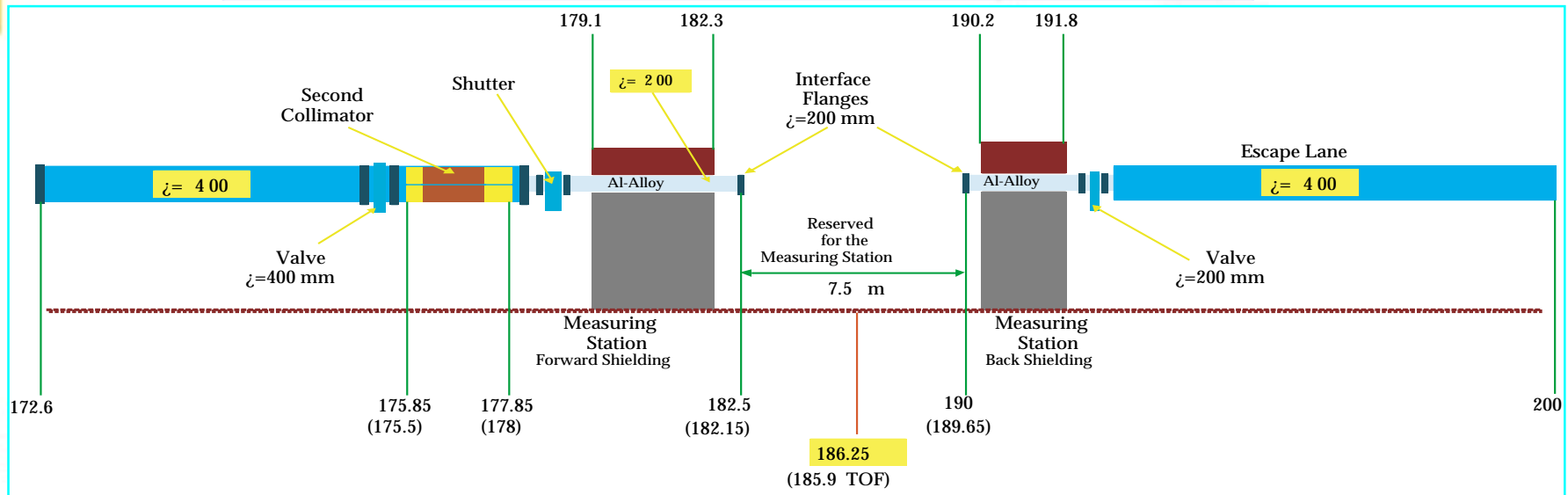

- ◆ Constructed according to the planned design [CERN/INTC 2000-018] and with the EP & TIS safety and radioprotection authorisation !
 - Aluminum honeycomb “*false floor*” for reducing neutron background, carbon fibre and “*minimum mass*” detector supports.
 - Front-End and trigger electronics in the detector vicinity and “*Gigabit Switch*” optical data transfer lines to the “*Control Room*”.
 - *Gas regulation systems* and specific cupboard for operating inflammable gases in the detector vicinity.
 - The “*Reaction Chamber*” and the “*Neutron Escape Line*”.

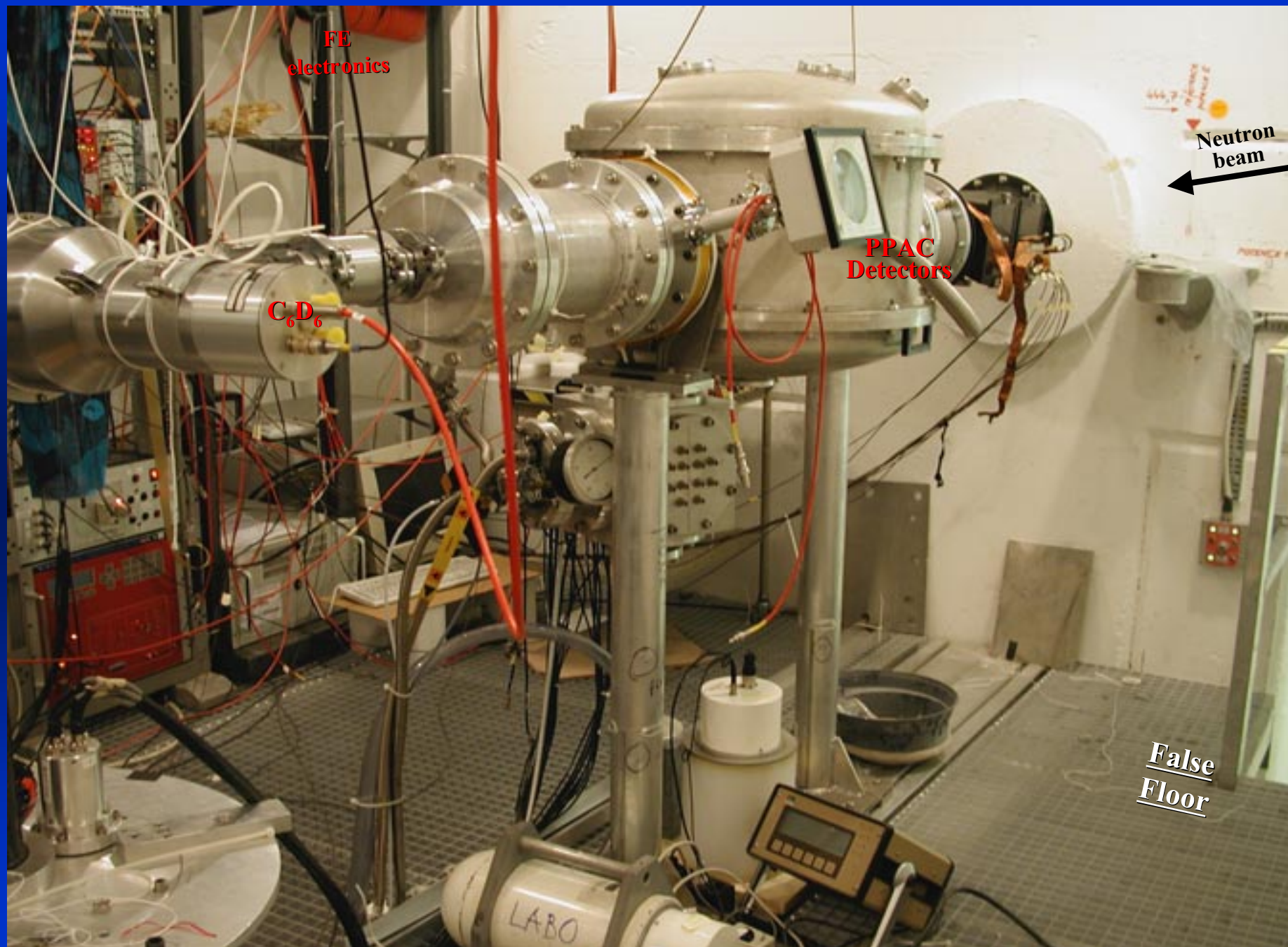

OBJECTIVES of the “ *n_TOF-ND-ADS* ”

- ◆ Measure with a precision of few % the appropriate **capture, fission** for elements with relatively well known cross-sections (^{197}Au , $^{24-26}\text{Mg}$, ^{207}Pb , ^{56}Fe , ^{235}U and ^{238}U) though their knowledge at high energies is still limited.
- ◆ Determine with a precision of few % the **capture cross sections** for the isotopes, relevant to the Th-cycle: ^{232}Th , ^{231}Pa , ^{233}U , ^{234}U , ^{236}U .
- ◆ Determine with a precision of few % **the capture cross sections** for the transuranic isotopes: ^{237}Np , ^{240}Pu , ^{242}Pu , ^{241}Am , ^{243}Am , ^{245}Cm .
- ◆ Determine with a precision of few % the **capture cross sections** of specific LLFF as ^{151}Sm , ^{99}Tc , ^{129}I , ^{79}Se , ^{93}Zr and further on $^{205,206,207}\text{Pb}$ and ^{209}Bi .

“*n_TOF-ND-ADS*” OBJECTIVES *Continue*

- ◆ Determine with a precision of few % the **fission cross sections** of:
 ^{232}Th , ^{231}Pa , $^{233-236}\text{U}$, ^{237}Np , ^{241}Am , ^{243}Am , ^{244}Cm and ^{245}Cm .
- ◆ Precise measurement of **(n,xn) cross sections** using also activation techniques of:
 ^{233}U , ^{232}Th , ^{231}Pa , ^{239}Pu , ^{241}Pu , ^{241}Am , ^{243}Am , ^{237}Np and ^{207}Pb .
- ◆ Measure the **total cross sections** of: ^{237}Np , ^{129}I , ^{239}Pu and ^{240}Pu .
- ◆ Measure **capture** and **fission cross sections** at **given neutron energies with mono-energetic beams** of the isotopes:
 ^{232}Th , ^{233}U , ^{237}Np , $^{241,243}\text{Am}$ and ^{99}Tc , ^{129}I , ^{79}Se , ^{151}Sm , ^{137}Cs .
 - **GELINA Time-Of-Flight at JRC-IRMM/Geel**
 - **Tandem (23 MeV) accelerator at NCSR “DEMOKRITOS” (Athens)**
 - **Van de Graff accelerators at INP (Lisboa), FZK (Karlsruhe) and CENBG (Bordeaux)**



- Neutron capture on light elements required in the analysis of stellar grains (Example: the **Mg isotopes ; P124**)
- Unstable isotopes involved in the *s*-process branchings to understand and analyze the physical conditions of stellar environment such as temperature, density, neutron-flux available for the nucleosynthesis (Example: **^{151}Sm ; P124**)
- Special cases which address to fundamental and open questions in nuclear astrophysics such as the age of the universe (Example: the **Re/Os nuclear cosmochronometer ; P125**)
- The capture cross sections for isotopes **^{204}Pb , ^{206}Pb , ^{207}Pb , ^{208}Pb , ^{209}Bi (P142).**
- The series of (n,α) cross section measurements on intermediate to heavy mass targets provide valuable constraints on (γ,α) and (α,p) reaction rates for studies of the nucleosynthesis occurring during the novae and supernovae explosion. (Example: the **α -particle width for the ^{64}Zn , ^{67}Zn , ^{95}Mo and ^{99}Ru n-resonances ; Pxxx)**
- The isotopes **^{90}Zr , ^{91}Zr , ^{92}Zr , ^{94}Zr , ^{96}Zr .**

With the nuclear data to be made available as **DataBases**, we can expect significant progress in the general understanding of the neutron capture nucleosynthesis.

Our Collaboration entangles competence and experience in:

- ◆ *Experimental Physics*
High performance detectors and data acquisition
- ◆ *Theoretical Physics*
Evaluation and Modeling of Cross Sections
- ◆ *Computational Physics, Data Bases and Visualization*
State-of-the-art computer engineering

Experimental Methodology

◆ Monitors

- MicroMegas Chambers
- Set of Si-detectors
- BF_3 long-counters

◆ Capture Cross Sections

- Set of C_6D_6 Detectors.
- Total Absorption Calorimeter
 - # 4π crystal calorimeter (e.g. FZK Ball) of BaF_2 or CeF_3
 - # Liquid Nobel Gas

◆ Fission Cross Sections

- Parallel Platte Avalance Chambers
- Multi-plate Coaxial Ionisation Chamber

◆ (n,xn) Cross Sections

- HPGe detectors
- Activation analysis

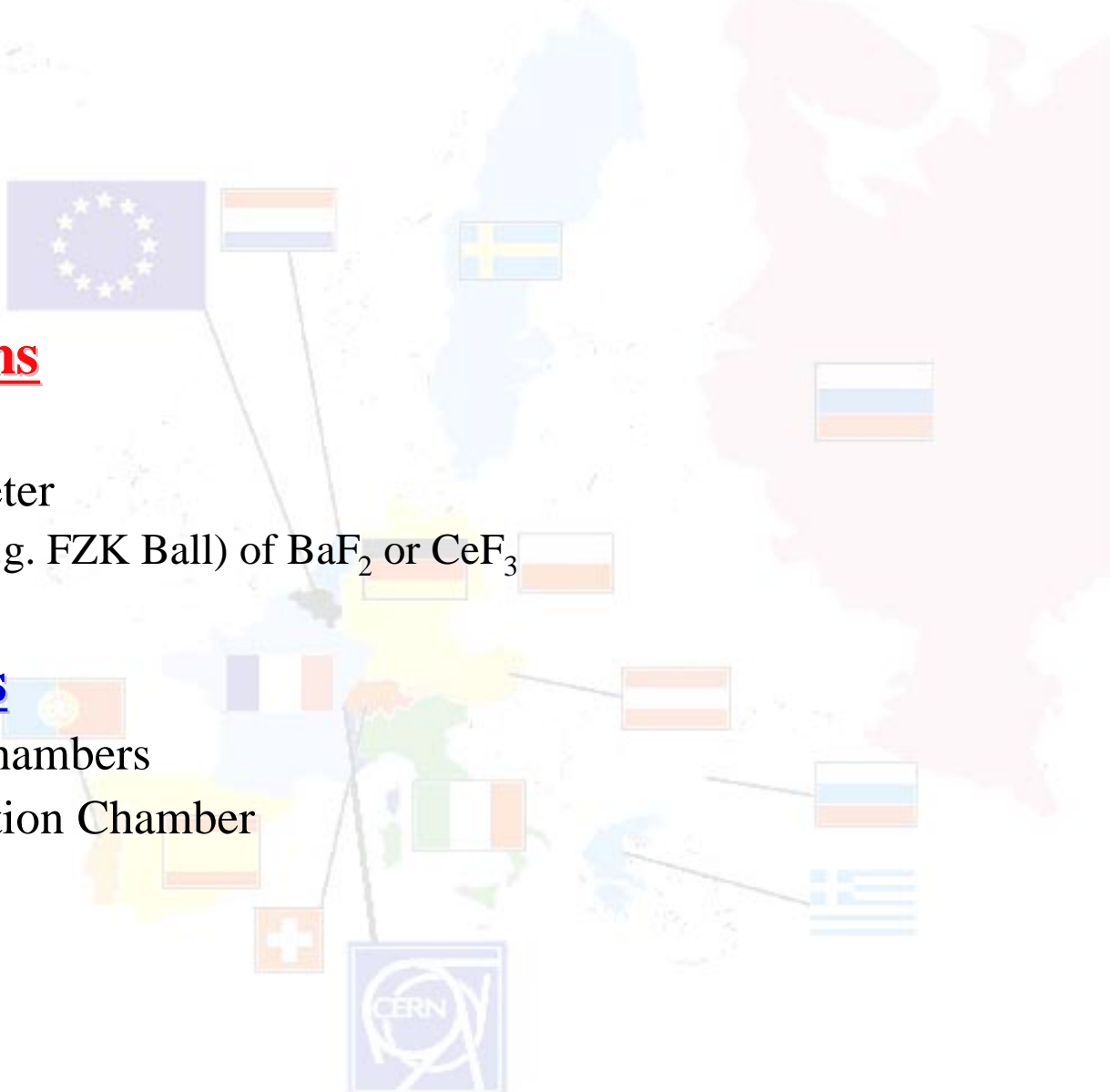

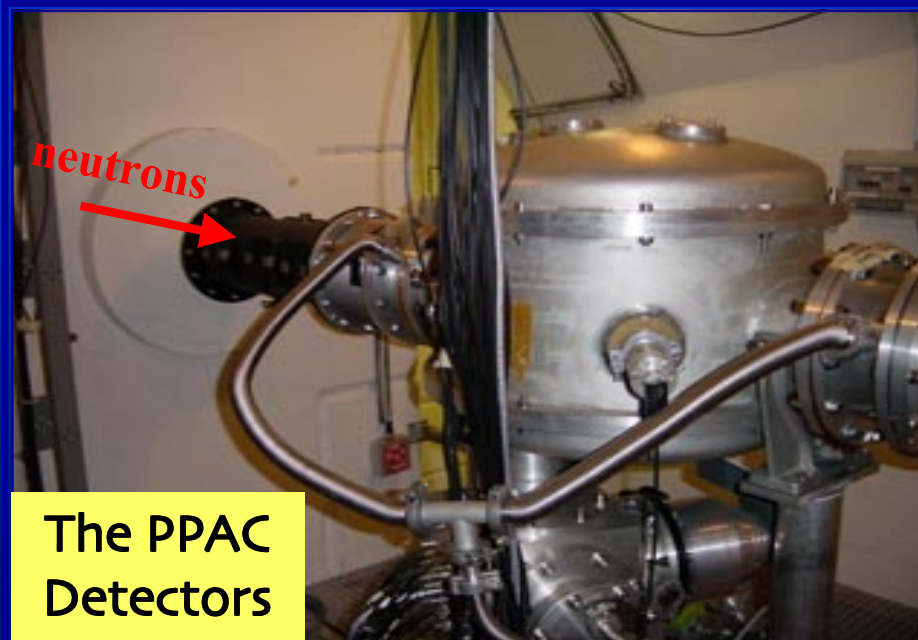

The PPAC Detectors

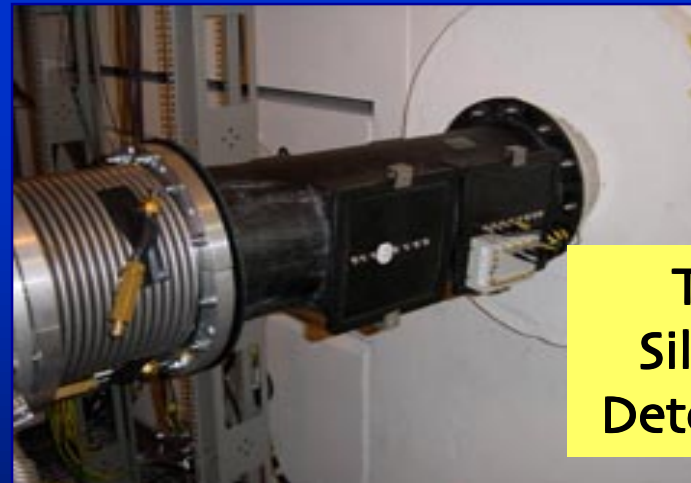

The Silicon Detectors



The MicroMegs Detectors



The C₆D₆ Detector

The Silicon Fluence Monitors

- ◆ Monitoring of the fluence as function of the neutron energy, but NOT the knowledge of the absolute value, since the determination of the cross section will be referenced to a “standard” isotope!
 - The ${}^6\text{Li}(n,\alpha){}^3\text{H}$ cross section is a “standard” in the E_n range from **thermal to 1 MeV**.
 - Measurement of the ${}^6\text{Li}(n,\alpha){}^3\text{H}$ reactions with **four 300 μm Si detectors** in vacuum.
 - A 3 cm diameter ${}^6\text{LiF}$ sample of $500 \mu\text{g}/\text{cm}^2$ on a substrate of $1.5 \mu\text{m}$ mylar.
 - The MC calculated Ω and the known $\sigma[{}^6\text{Li}(n,\alpha){}^3\text{H}] \Rightarrow$ **Neutron Fluence over beam surface**.
 - Dedicated calibration of the sample thickness and homogeneity of the sample will allow a **precision of a few percent**, as compared to the present 10% (MC).
 - Counting rates \propto neutron fluence \Rightarrow counting rates monitor the **neutron beam stability**.

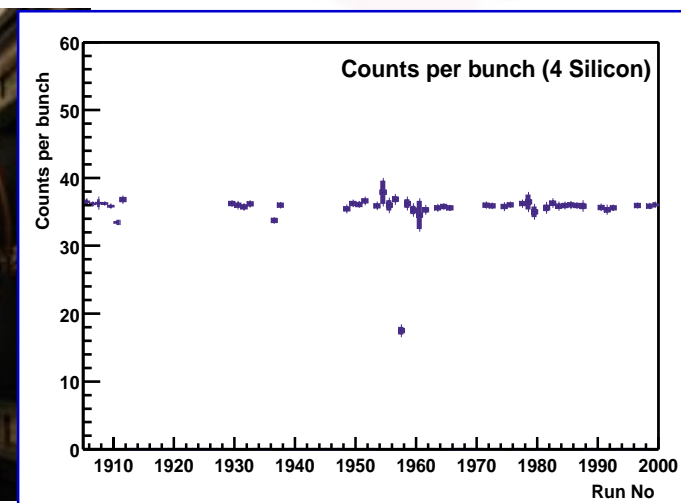
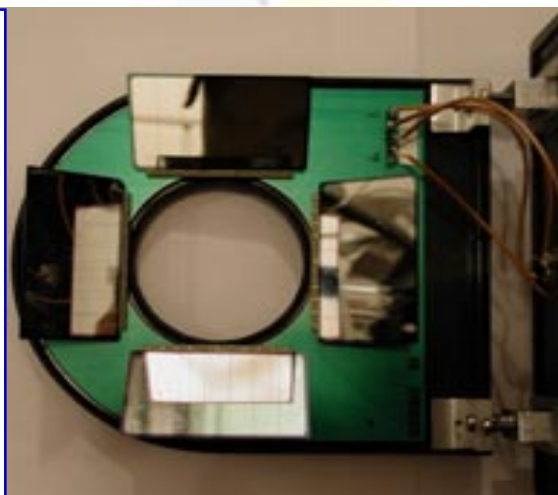
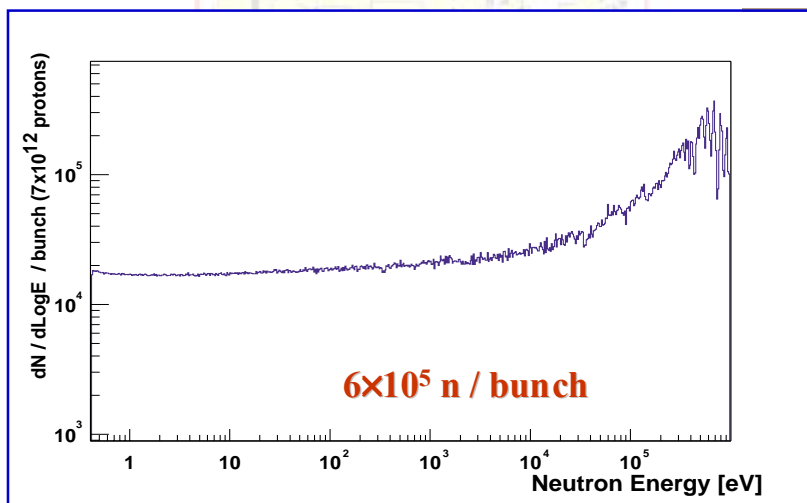

The “*MicroMegas*” Detector

- ◆ Fast detector with good time and spatial resolution.
- ◆ Filled with Helium is insensitive to the “ γ -flash”.
- ◆ Equipped with ${}^6\text{Li}$ \Rightarrow Beam profile and homogeneity, *but also monitors the beam stability.*
- ◆ Filled with H_2 -rich gas, increased sensitivity to higher energies (*Efficiency should be better understood*).
- ◆ First successful operation as position sensitive “*Neutron Counter*”
 \Rightarrow “*S.Andriamonje et al., NIM 2001, in print*”.

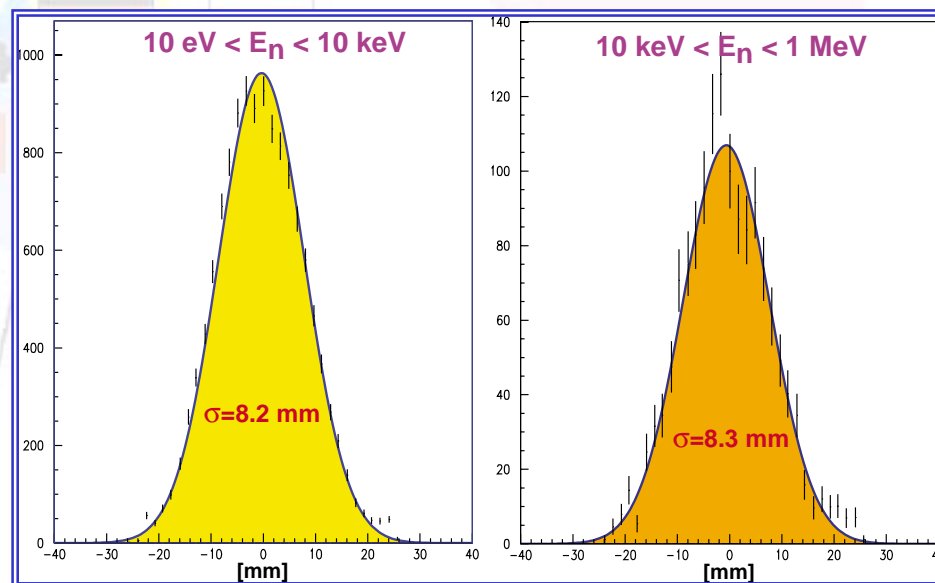
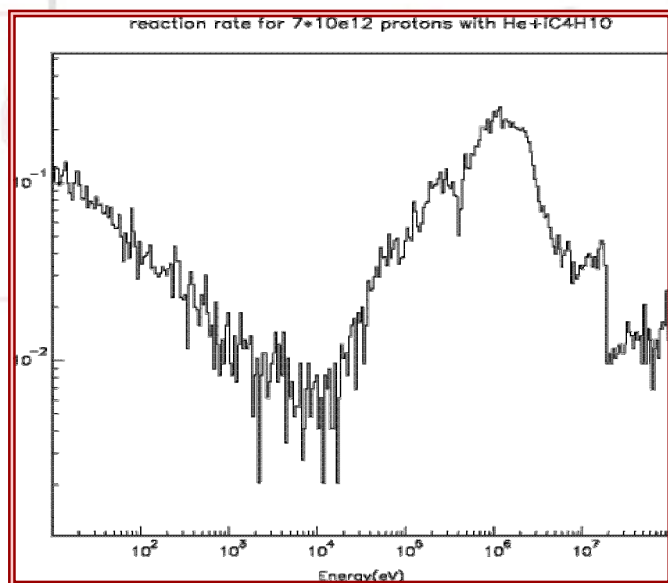

C_6D_6 Detectors

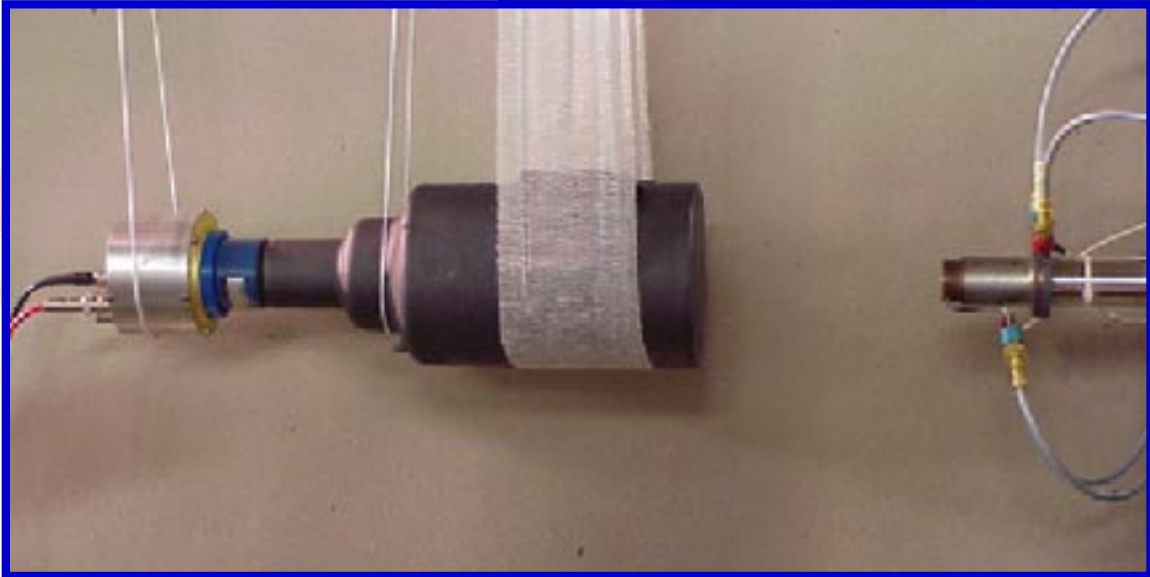
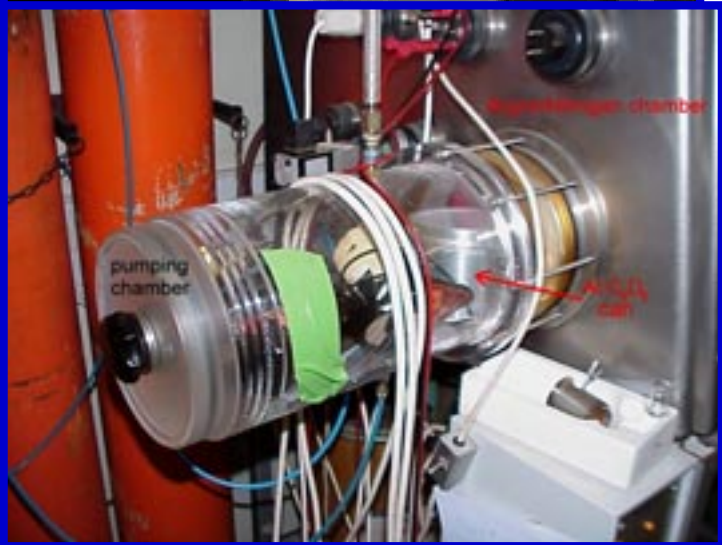
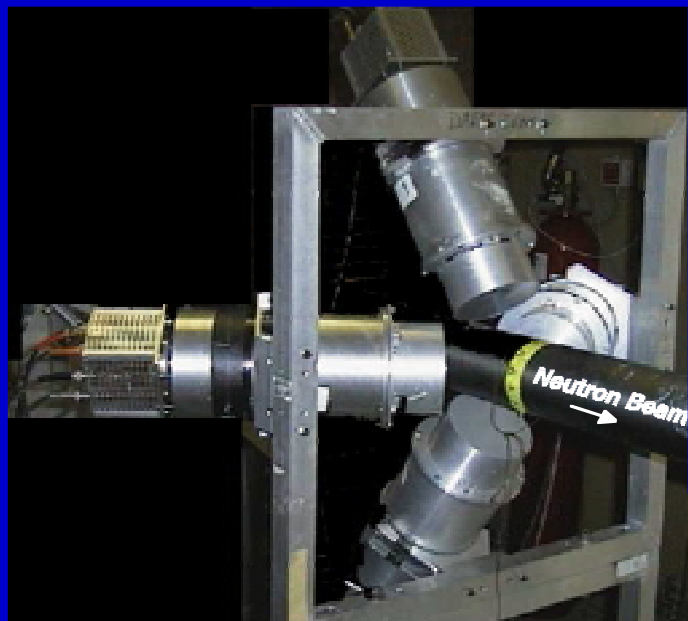

Improvement by the additional shielding

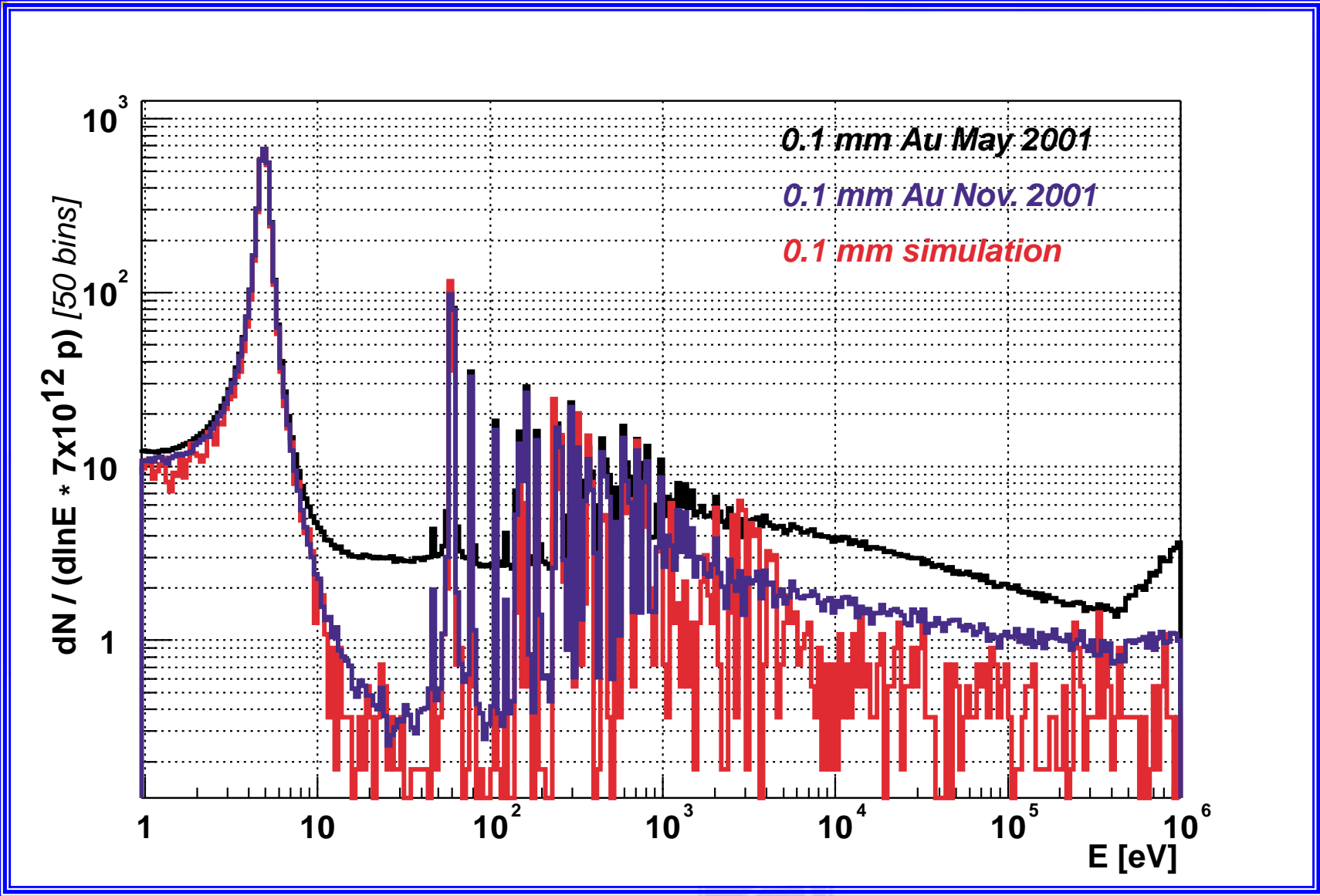

Total Absorption Calorimeter

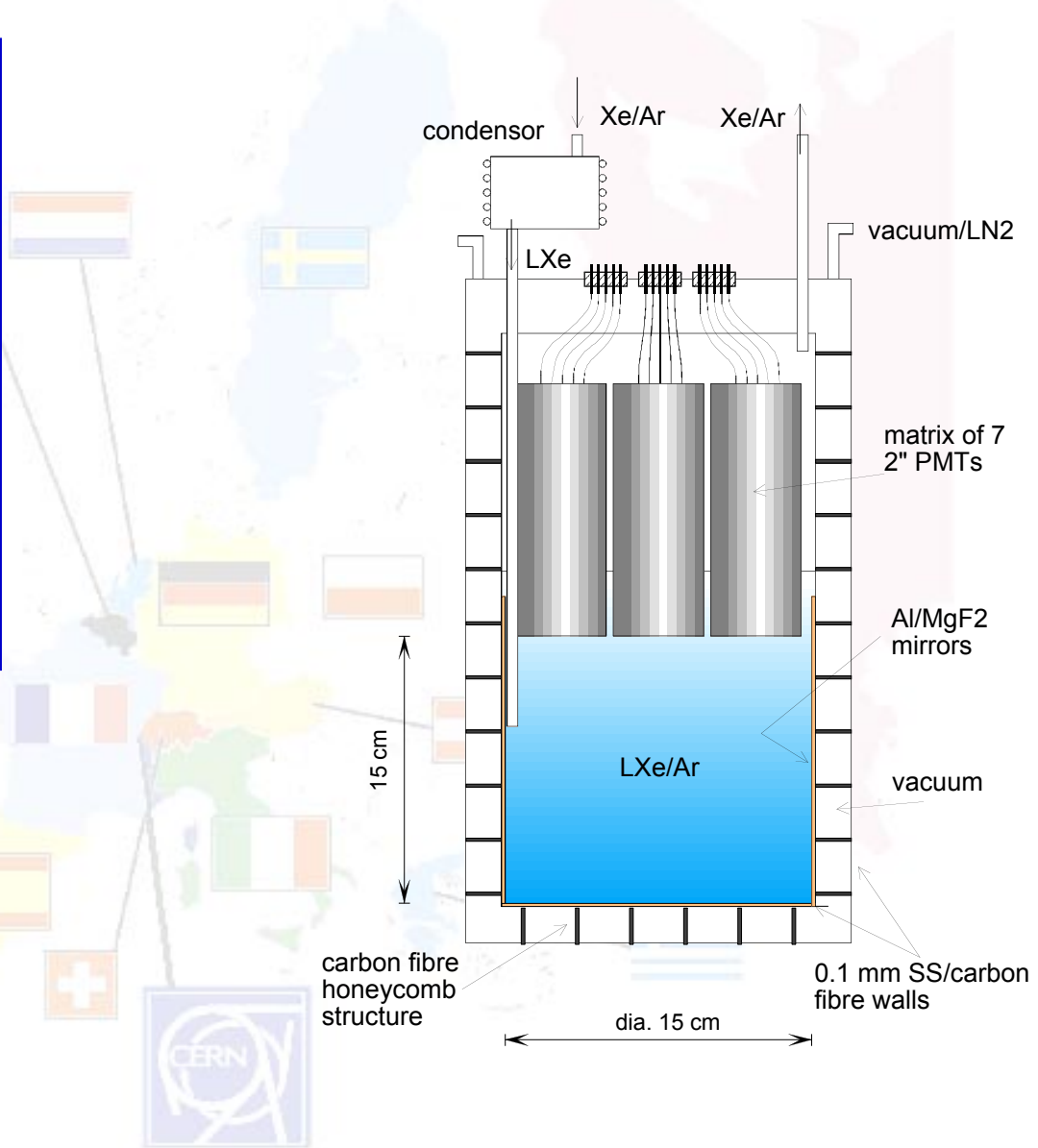
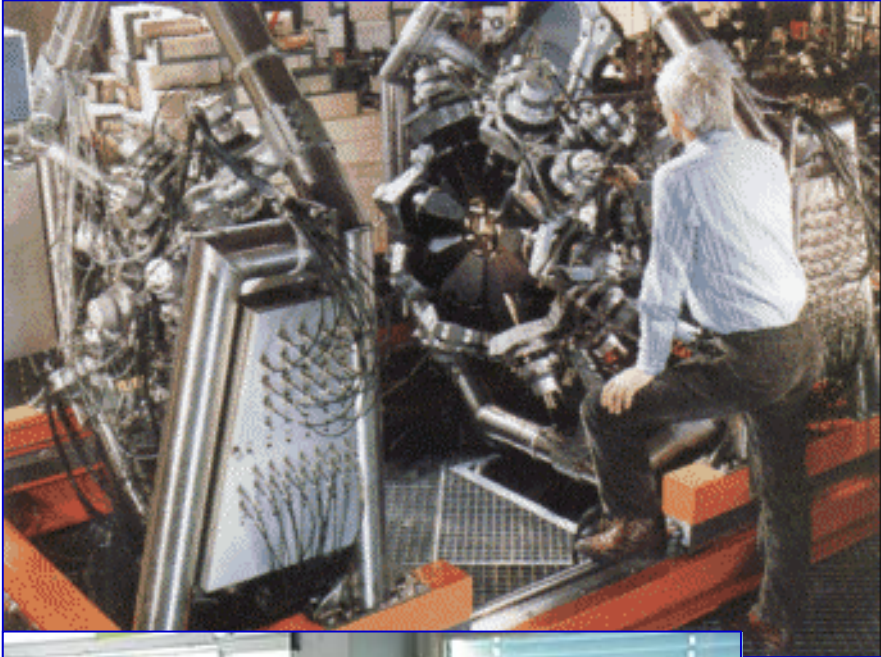

Fission detectors

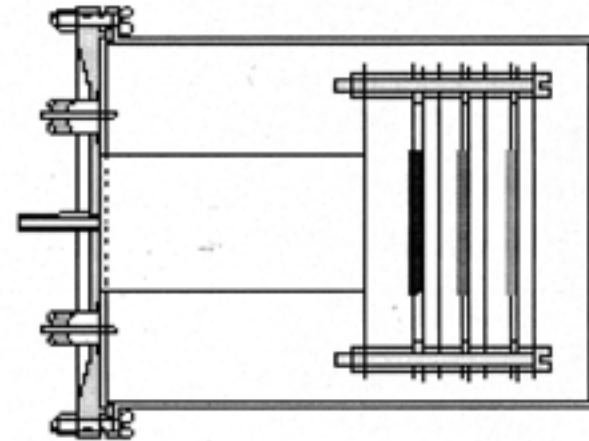
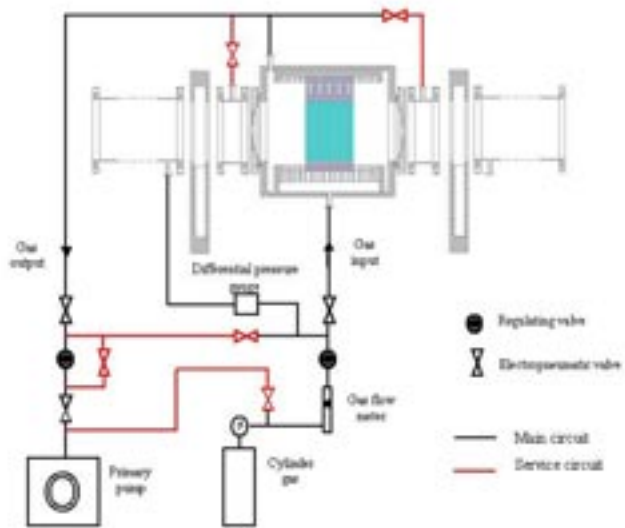
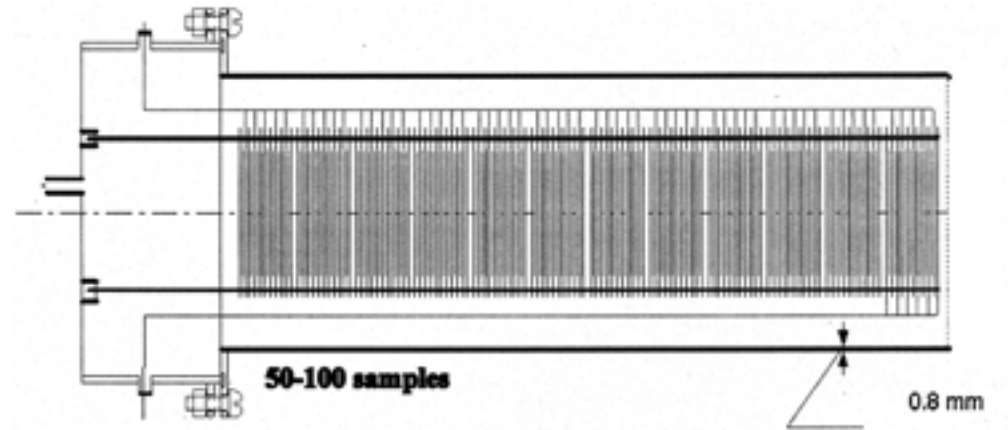
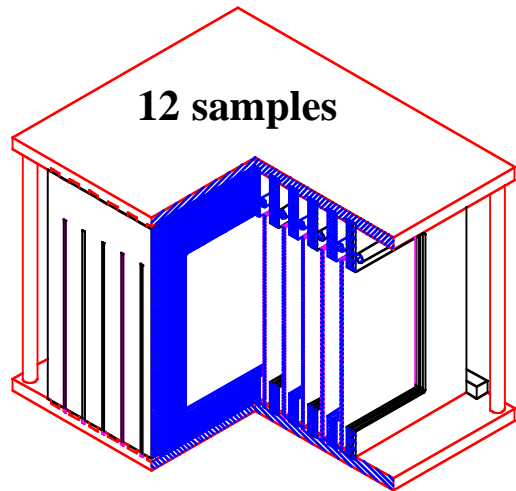



The PPAC Fission Detectors

- ◆ A set of 5 PPAC equipped with ^{235}U , ^{238}U and ^{209}Bi fission samples covered the neutron energy range from *thermal to 200 MeV*.
- ◆ The achieved energy resolution is excellent, but needs to be confirmed at higher energies (Doppler broadening less important). The *peak-to-valley* seems to be larger in the n_TOF data, indicating the expected good energy resolution.

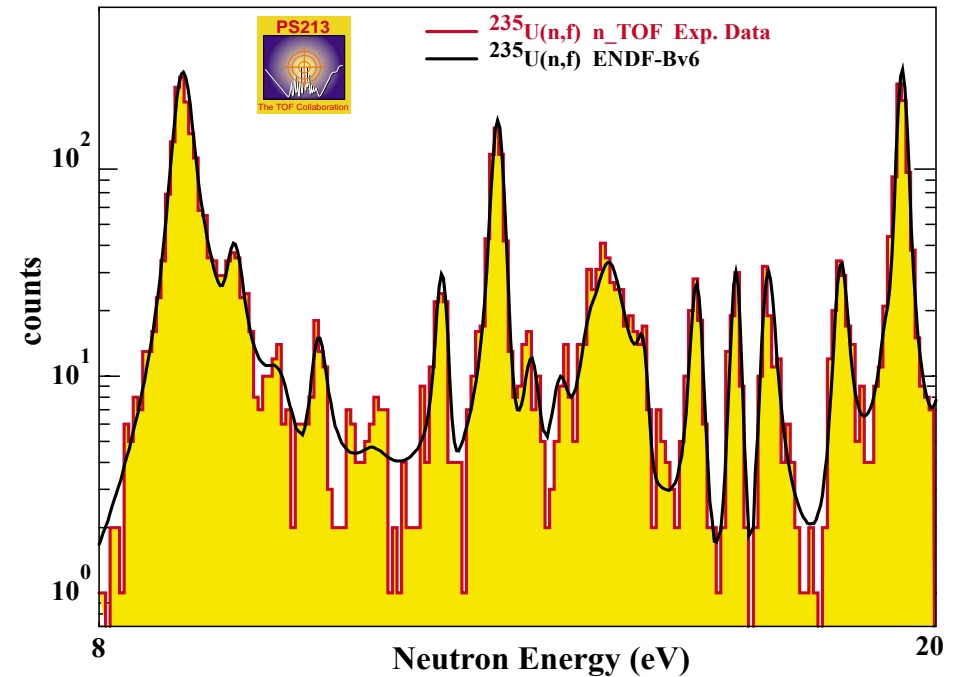
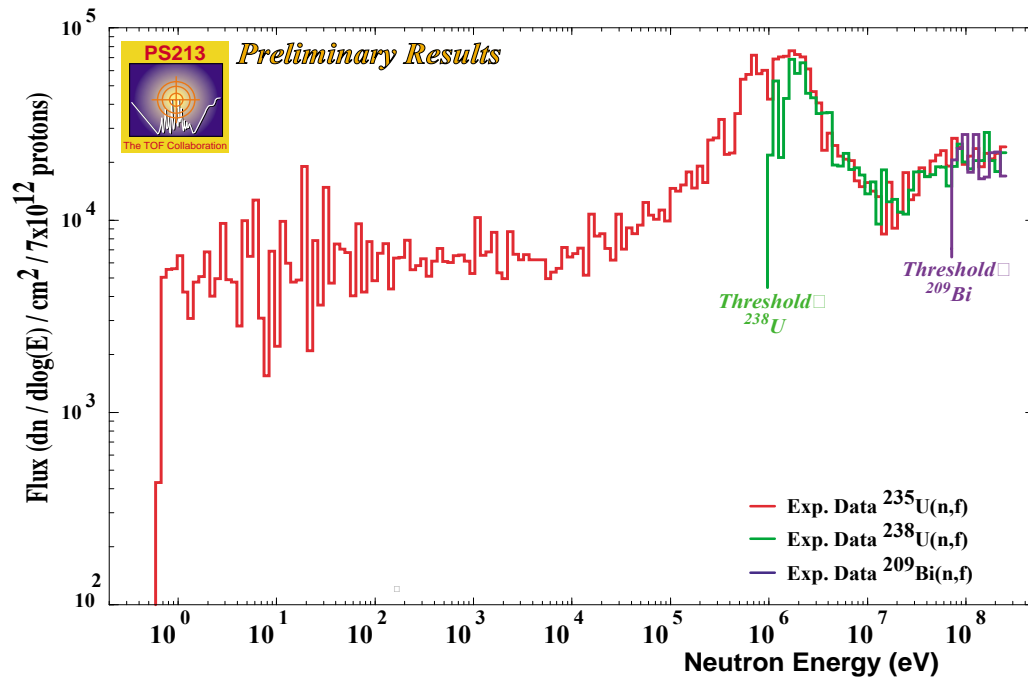

The measurements covers 8 orders of magnitude, proofing the power of the n_TOF method, using spallation neutrons from high-energy proton beam.

Nuclear Data Evaluation

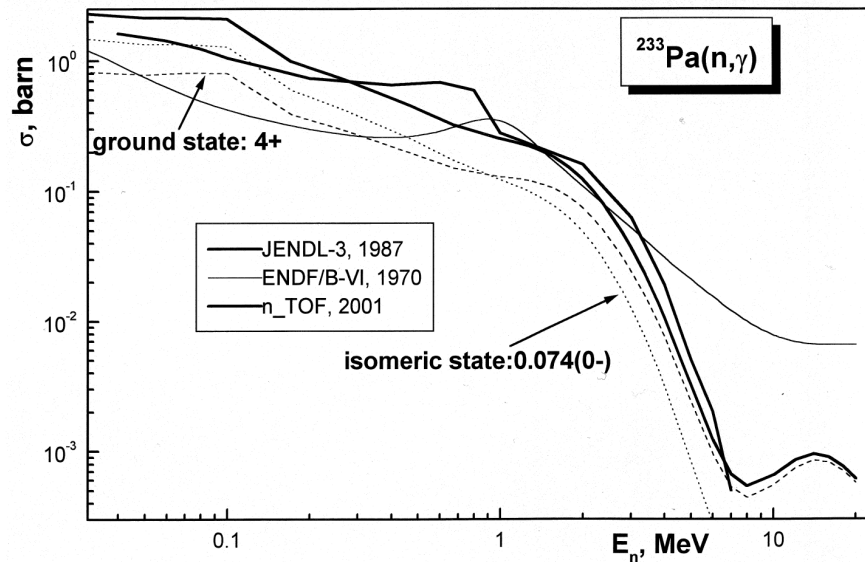
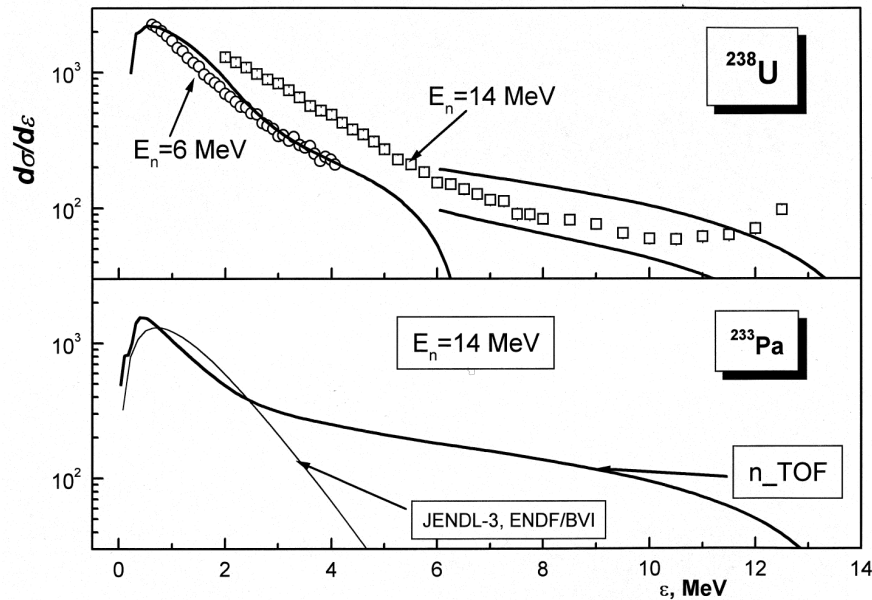
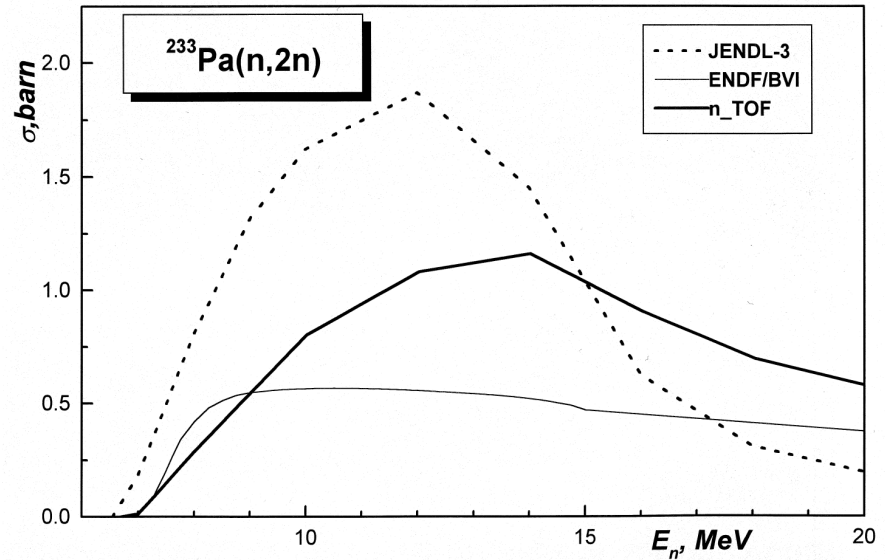
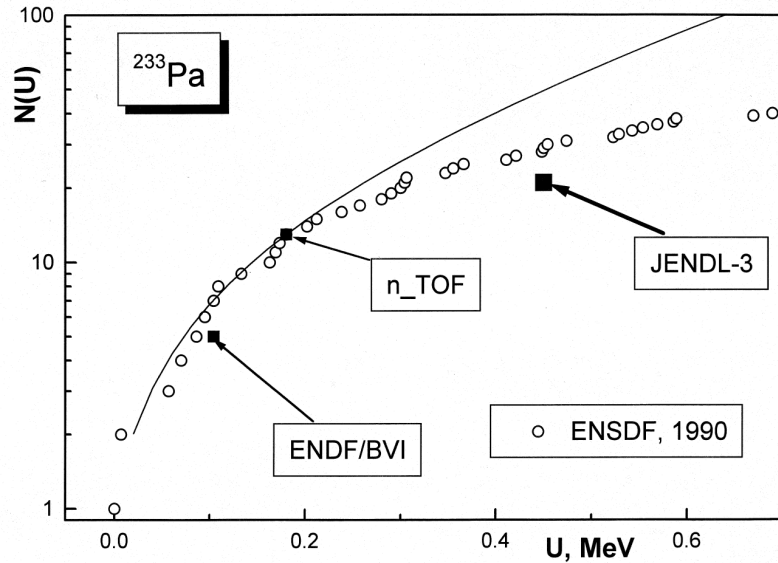

Nuclear Data Dissemination

- ◆ Take profit from the CERN Software Tools, i.e. ROOT.
- ◆ Compatible with the international tools of NEA/OCDE & IAEA.
- ◆ Goal is the n_TOF DataBase, *co-operation with NEA/OCDE & JEF.*

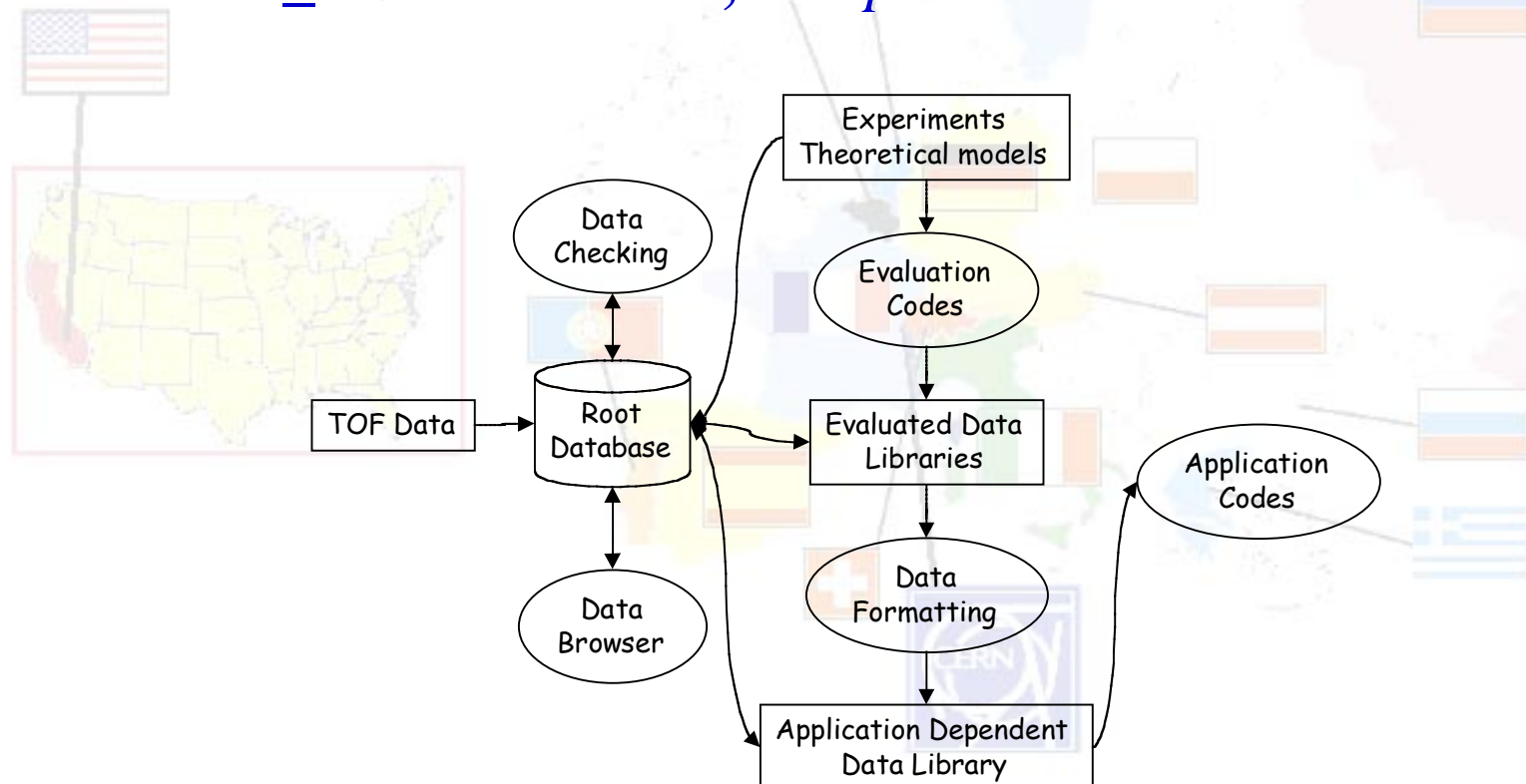



Monte Carlo Simulation

Neutron flux distribution

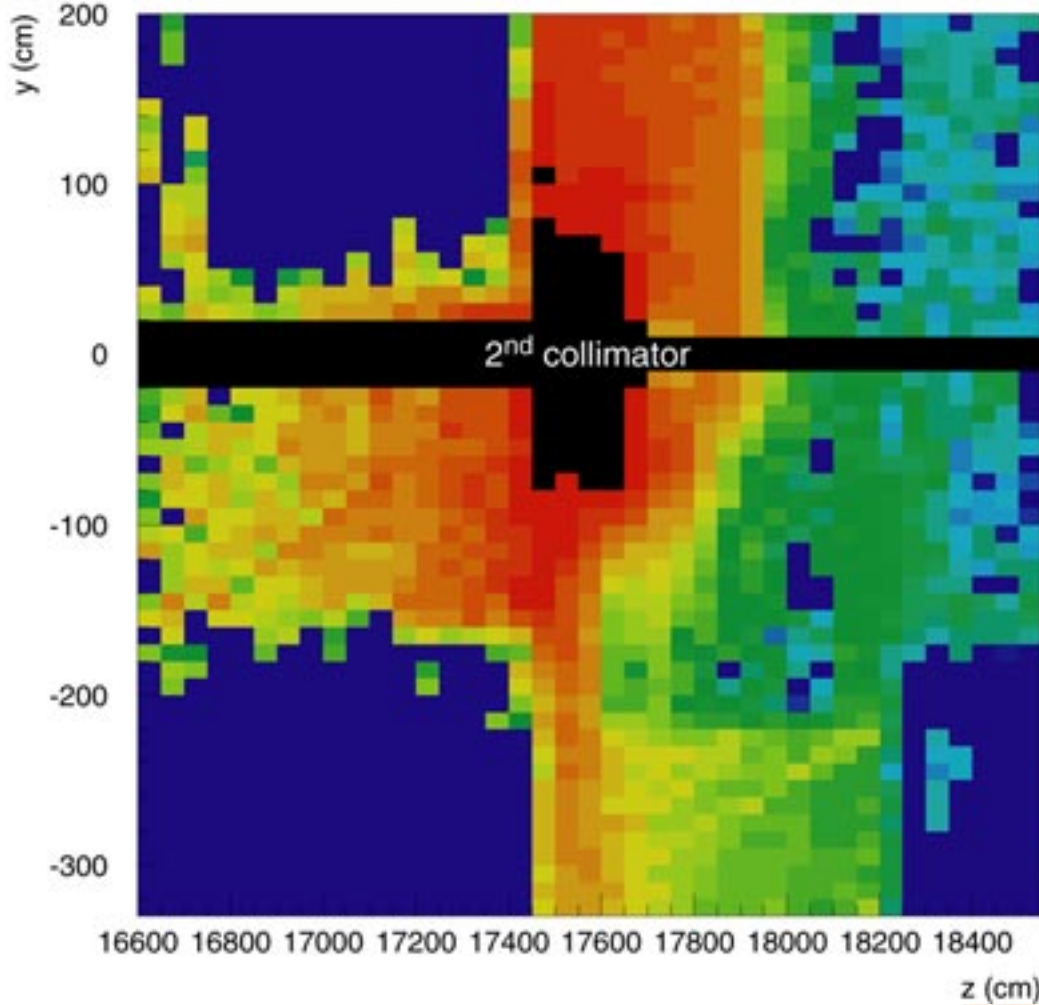

Radial neutron beam profile distributions at the sample position

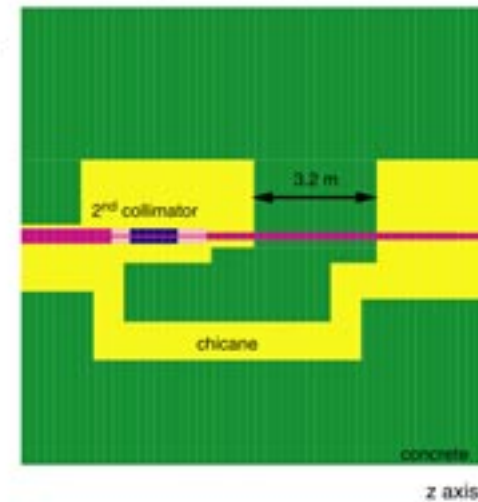
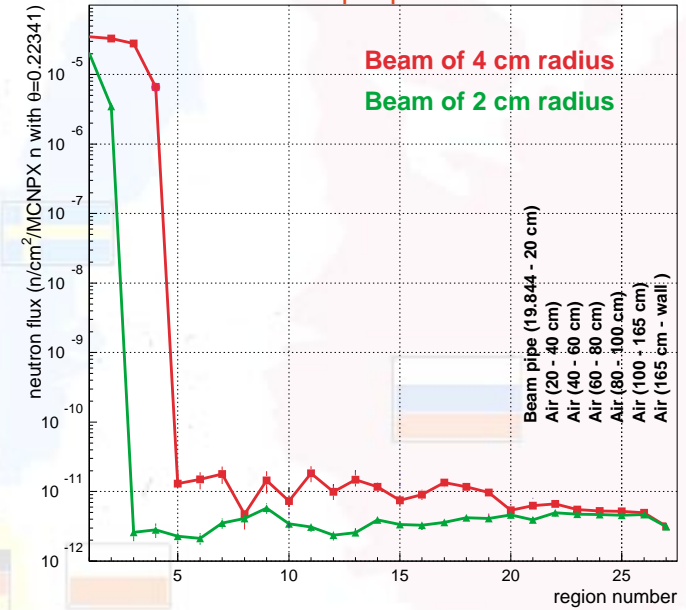

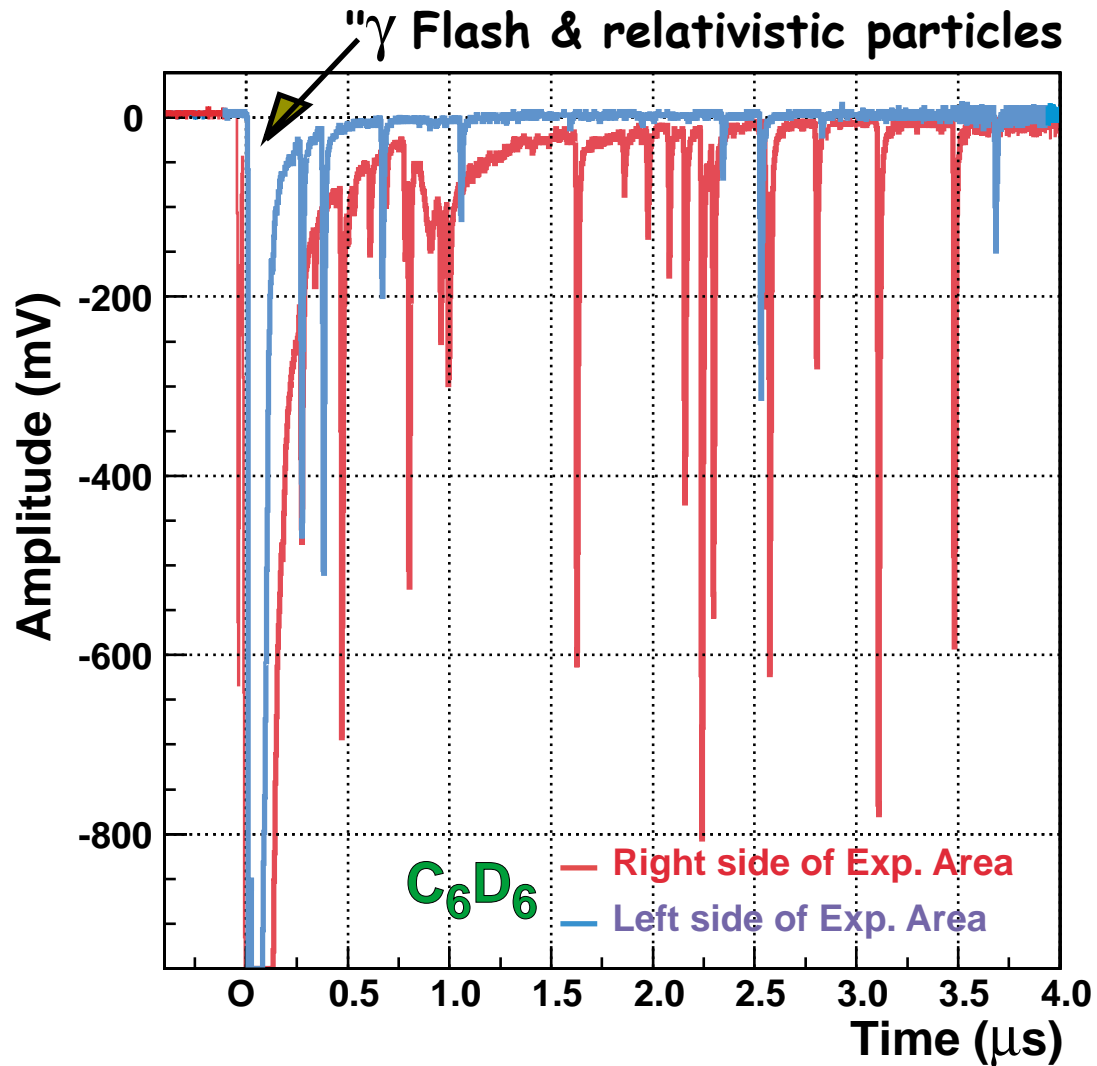

" γ Flash" & relativistic particles

Run: 1911 event: 1

